

Turnstile

Tx1500

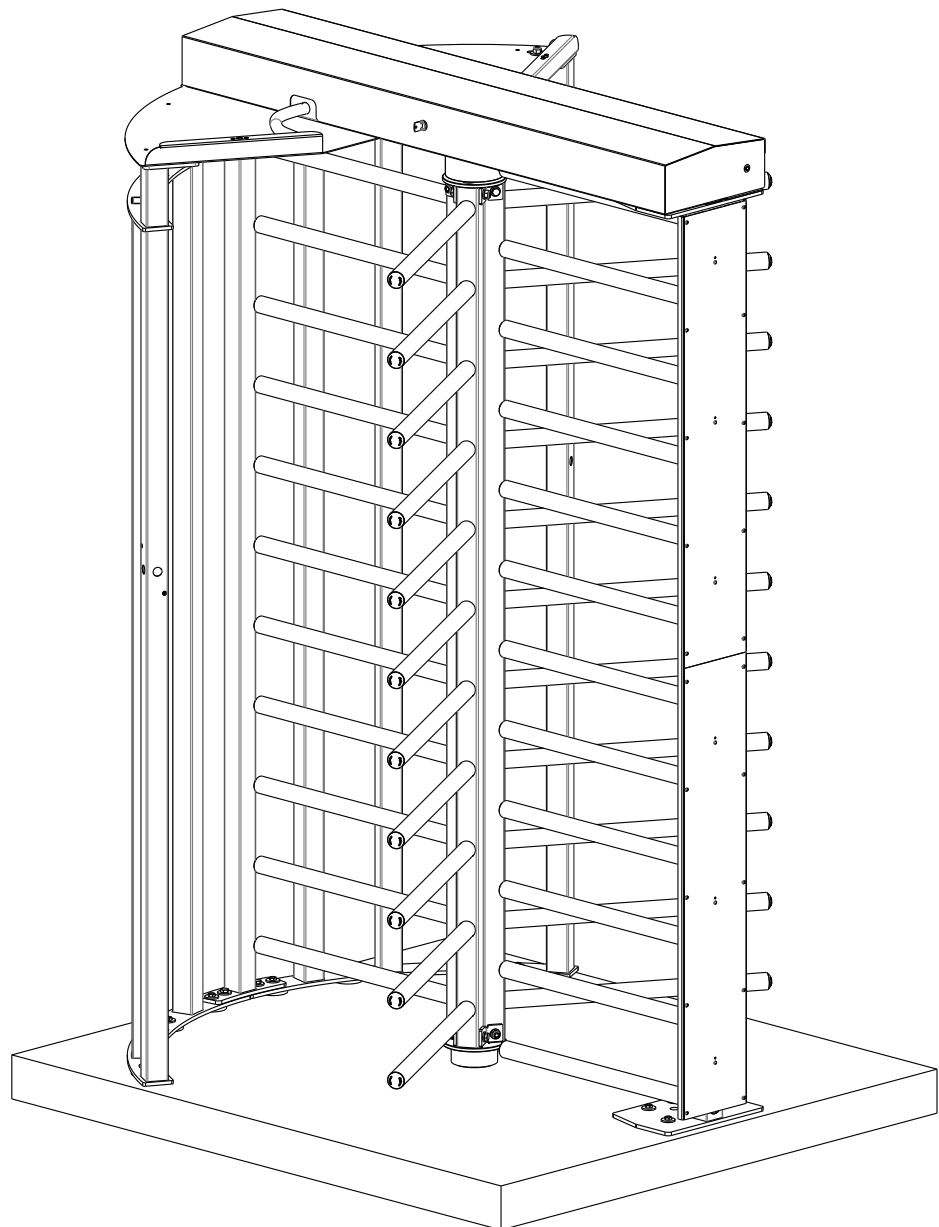

digicon

© Copyright– Digicon S.A.
Controle Eletrônico para Mecânica – 2013

All rights reserved. No part of this publication may be reproduced, transmitted, transcribed, stored in a retrieval system, translated into any language or computer language in any electronic, magnetic, optical, chemical, manual way, or otherwise, without the express written permission from Digicon S.A.

Códe: 069.31.211
Version: 01

This manual was elaborated by:

Digicon S.A. Electronic Control for Mechanics Documentation Sector - EDS

Contents

1. IMPORTANT INSTRUCTIONS	05
2. ORIENTATIONS	06
3. INTRODUCTION	06
4. INSTALLING Tx1500	07
5. CAPTIONS	23
6. POWER SUPPLY	25
7. CONTROL BOARD	25
7.1.INPUTS	27
7.2.OUTPUTS	28
7.3.CONFIGURATION OF CONTROL BOARD - SWITCHES DS1 AND Ds2	30
7.4.EXAMPLES OF SOME CONFIGURATIONS	30
7.5. SERIAL COMMUNICATION	31
8. DIMENSIONS	32
9. WARRANTY AND TECHNICAL ASSISTANCE	33

1. Important instructions

You can see, below, the symbols that will appear in this manual, signaling important moments. It is essential to pay attention to them.



TIP: Indicates something Digicon considers important.



CAUTION: Indicates a moment of extreme caution when handling the equipment/product



ATTENTION: Indicates a moment when your observation skills should be extremely productive.



INFORMATION: Presents interesting facts about the purchased product.



QR CODE: Presents additional information or links with more details about the presented text.

2. Orientations

- Read the information and instructions of this manual carefully, before using the product. This ensures the correct use of the equipment and maximum use of its technical features as well as a prolonged service life.
- Keep this manual for future consultations.
- Digicon reserves its right to alter its products at any moment to adapt them to more recent technical advancements.
- Digicon maintains its right to alter the information contained in this manual without previous notice.
- Digicon does not provide any contractual warranty concerning the information in this manual, and cannot be held responsible for errors it may contain and problems due to its use.
- The information contained in this manual is exclusive property of Digicon and is protected by copyright laws.
- This manual cannot be reproduced, photocopied or translated, in its entirety or in part, into any kind of medium, without Digicon's written consent.

3. Introduction

The Full-height **Turnstile Tx1500** is a bidirectional access control equipment for entrance and exit of pedestrians. Highly resistant, both indoors and outdoors, it is sturdy, safe, and firmly fixated to the floor. It is completely integrated to access controllers. This manual presents a detailed description the installation of **Tx1500** and of the components that accompany it.

To see our complete catalogue, visit www.digicon.com.br.



4. Installing Tx1500

1th Step: Prepare the Turnstile assembly

The floor where the turnstile will be fixed must meet the following specifications:

- a. Dimensions: Direction of flow 1,6m x lcolumns width 1,4m x concrete height 10 cm;
- b. Necessary height: 2.5 meters;
- c. Level the floor for better product performance;
- d. Floor specification (FCK15 M.P.A. concrete or equivalent);
- e. Floor specification (FCK15 M.P.A. concrete or equivalent) 1,6m x 1,4m x 2,6m.



INFORMATION: Illustrative image (measures specified in "mm").

Power point input and network cable can be on the floor, preferably at point 3 or overhead pipes.

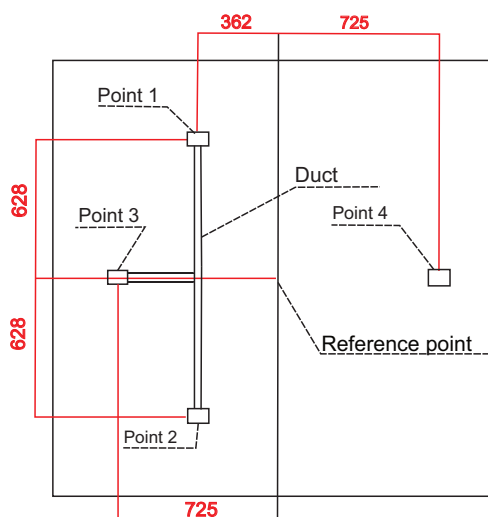

Obs.: The dimensions of the concrete block and power inputs are only a suggestion. The client can choose smaller bases (footing) at the fixing points (determined by template).

List of tools for assembling the Turnstile:

- 1 socket wrench with socket of 14 and 17mm;
- 1 combination wrench 17;
- 1 socket wrench 10 with extension;
- 1 n.3 Allen wrench;
- 1 n. 5 Allen wrench;
- 1 medium-sized Philips screwdriver;
- 1 medium-sized screwdriver;
- 1 hard plastic hammer
- 1 plum-line or water level;
- 1 silicone tube;
- Molykote BR2 Plus graphite grease;
- Step ladder with four steps;
- Electric drill and drill bits for concrete with 6 and 14 cm;
- Bolter – 10 parts for every product.

2th Step: Drilling device

- a. It will be necessary to add cardboard or bubble wrap under the device so not to damage the roof painting when using the drilling demarcations;
- b. Screw the device (P1) to the turnstile's roof (P1);
- c. Position the assembled parts in the area chosen for installation, observing the flow of entrance and exit;
- d. Observe the desired side for the opening (lock side) of the central support for maintenance;
- e. Place the roof (P1) and fix tem with screw (P2) and nut (P3);
- f. The pre-hole must be done with an Ø6mm drill, so there are no damages to the device's holes;
- g. Remove the device and drill again all the holes with an Ø14mm drill.



ATTENTION: *The place of installation and the direction of entrance and exit must be defined alongside the responsible for the place.*

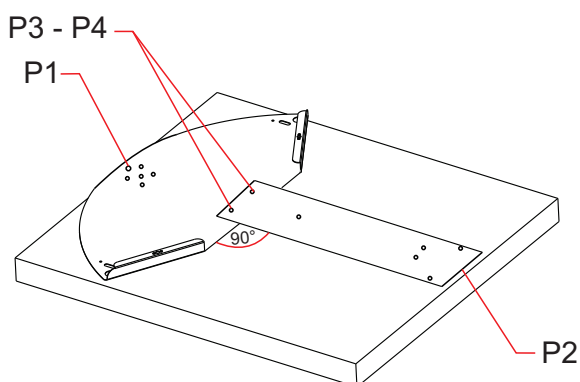

Quantity of parts used in this stage:

- P1 = 1x Roof
- P2 = 1x Drilling device
- P3 = 2x Allen screw M6x15
- P4 = 2x Nut M6

Obs.: After all demarcations, disassemble the device to use the part later (P1).

3th Step: Assembly of sides with rods or glass sides

Sides with rods:

- a. Fit the sides (P5) and (P6) so to form an arch;
- b. Screw the sides using washer (P7) and screw (P8); repeat on the four fixing points (two on the upper part, two on the lower part);
- c. Place the screw (P26) with washers (P7) on both sides and on the nuts (P18) to finish the holes on the arch's upper part.

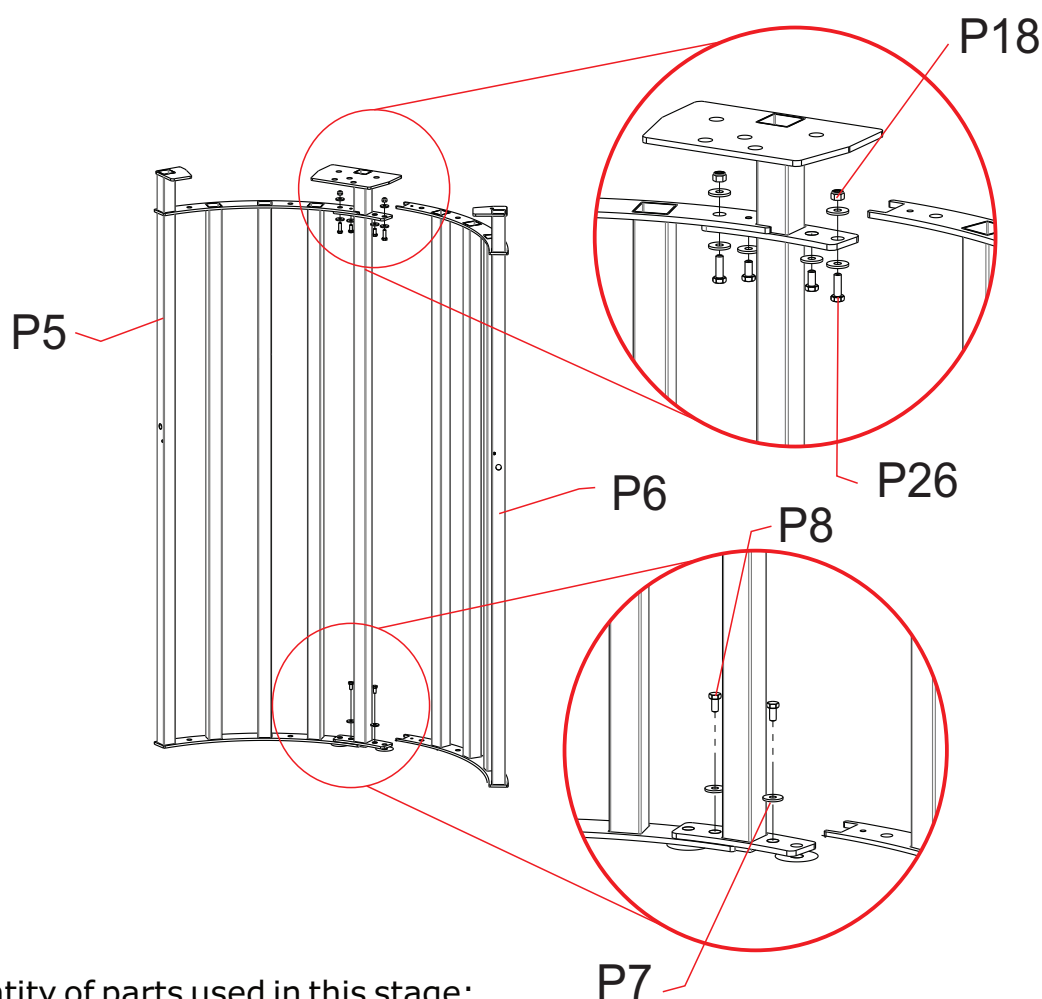

Quantity of parts used in this stage:

- P5 = 1x - 5 side rods
- P6 = 1x - 4 side rods
- P7 = 8x - Washer D=30,5 x 10,5 x 3mm
- P8 = 4x - Hexagon head screw M10 x 20
- P18 = 2x - Nut M10
- P26 = 2x - Hexagon head screw M10 x 30

This assembly will result in the set (P23) – Assembling the arch's sides

Glass sides:

- a.** Fit the sides (P39) and (P40) so to form an arch;
- b.** Screw the sides using washer (P41) and screw (P8); repeat on the four fixing points (two on the upper part, two on the lower part);
- c.** Fix the glass support (P42) to the rods' inner parts using washers (P25) 2x and screws (P20) 2x in each support;
- d.** Fit the nut for the glass support (P45) to the glass support (P42); after the nut was placed on the other side, place the two PVC washers (P44);
- e.** Repeat items "c" and "d" 16 times in each support fixation.

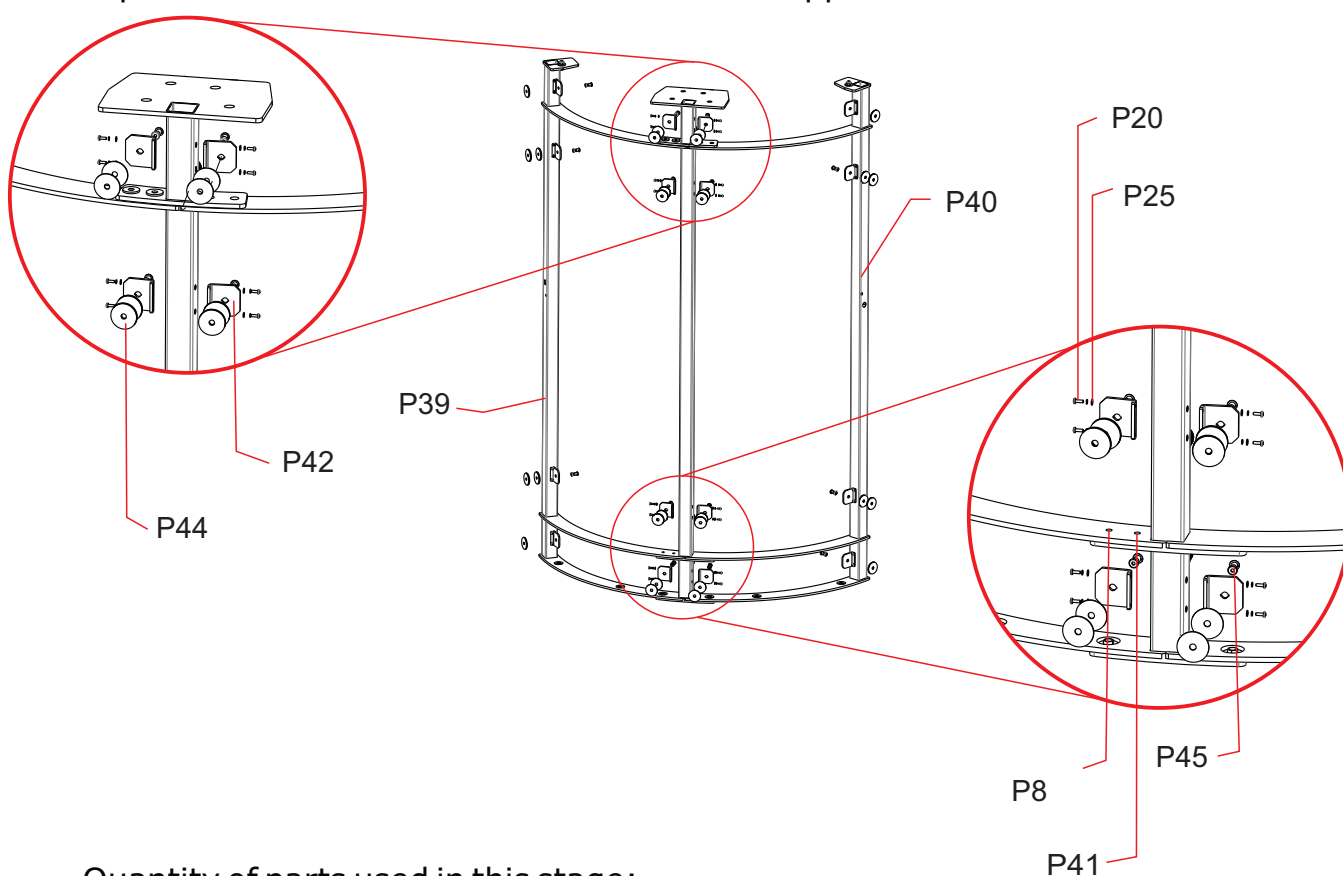

Quantity of parts used in this stage:

- P8 = 4x - Hexagon head screws M10 x 20
- P20 = 32x - cross head screw M4 x 12
- P25 = 32x - flat washer D4
- P39 = 1x - 2 side rods
- P40 = 1x - 1 side rod
- P41 = 4x - flat washer D10
- P42 = 16x - glass support
- P44 = 32x - PVC washer
- P45 = 16x - glass support nut

This assembly will result in the set (P48) – Assembly of glass sides.

4th Step: Assembling central arms

- a.** fix the inner triangle (P9) to one of the arms (P10) using the screw and the spring washer (P11); repeat it for the arm's two fixing points (P10). Fixing this part is done internally in the arms that have no buffer. Do not fasten the screw, simply position it.
- b.** Place the second arm (P10), fixing it to the inner triangle (P9) using the screw and the spring washer (P11). Repeat it for the arm's two fixing points (P10). Fixing this part is done internally in the arms that have no buffer. Do not fasten the screw, simply position it.
- c.** Place the third arm (P10), fixing it to the inner triangle (P9) using the screw and the spring washer (P11). Repeat it for the arm's two fixing points (P10). Fixing this part is done internally in the arms that have no buffer. Do not fasten the screw, simply position it.
- d.** Fit the lower base set (P14) to the lower part of the assembled arms (P10); place the washers (P17) 2x, screw (P16) 1x, and nut (P18) 1x in each of the holes 3x. Do not fasten the screw to the nut, only position it.
- e.** Fit the upper base set (P15) to the upper part of the assembled arms (P10); place the washers (P17) 2x, screw (P16) 1x, and nut (P18) 1x in each of the holes 3x. Do not fasten the screw to the nut, only position it.

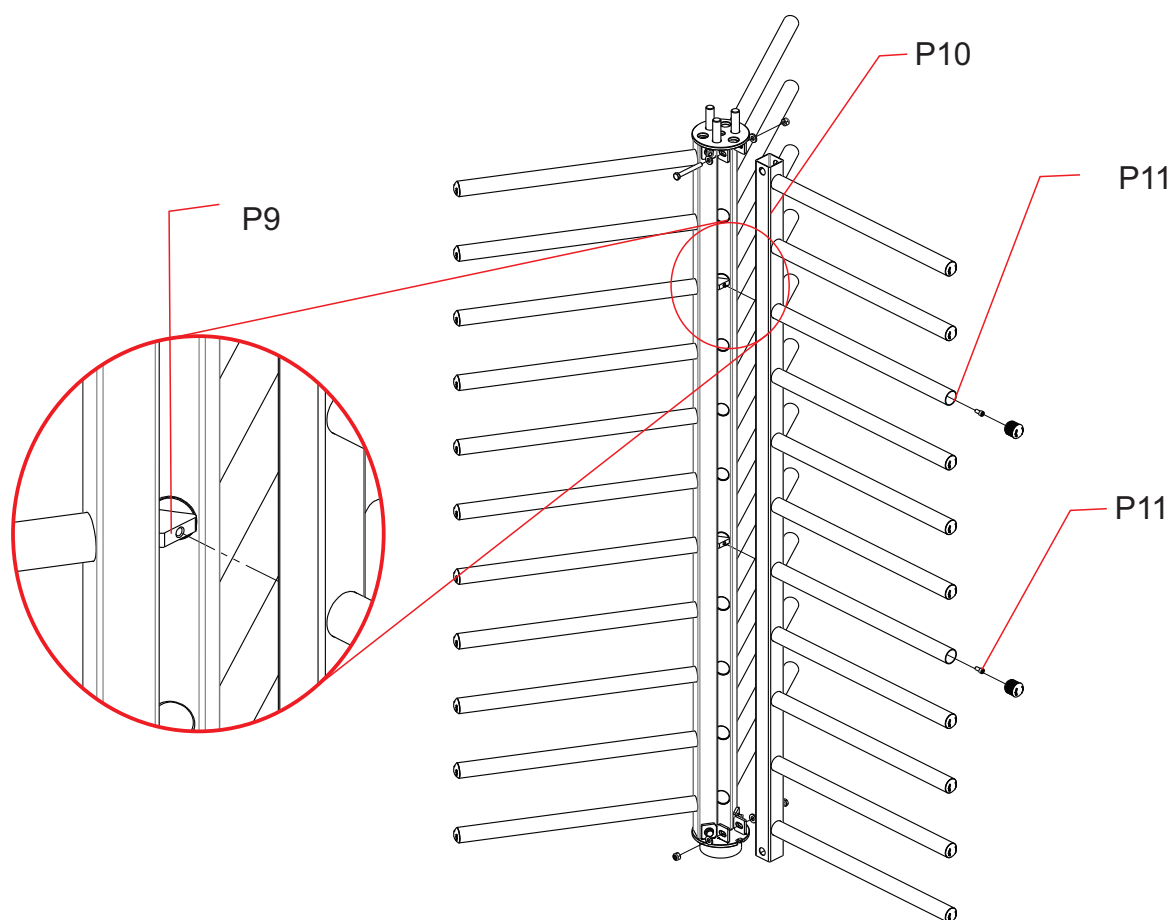

Base set assembled. Do not fasten it.

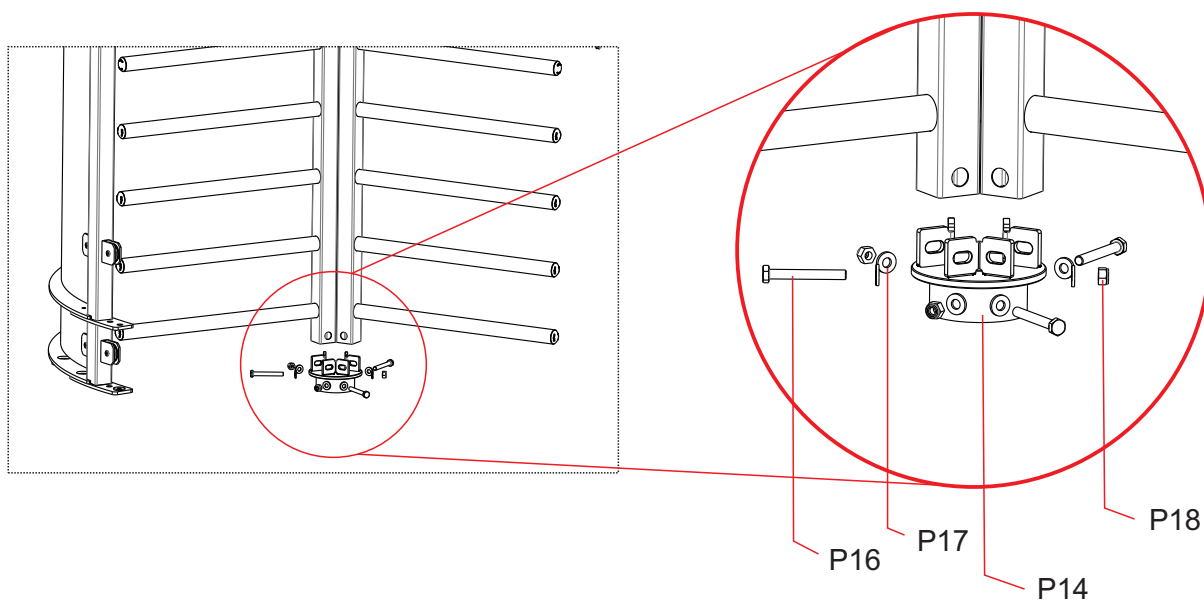

Upper base set assembled. Do not fasten it.

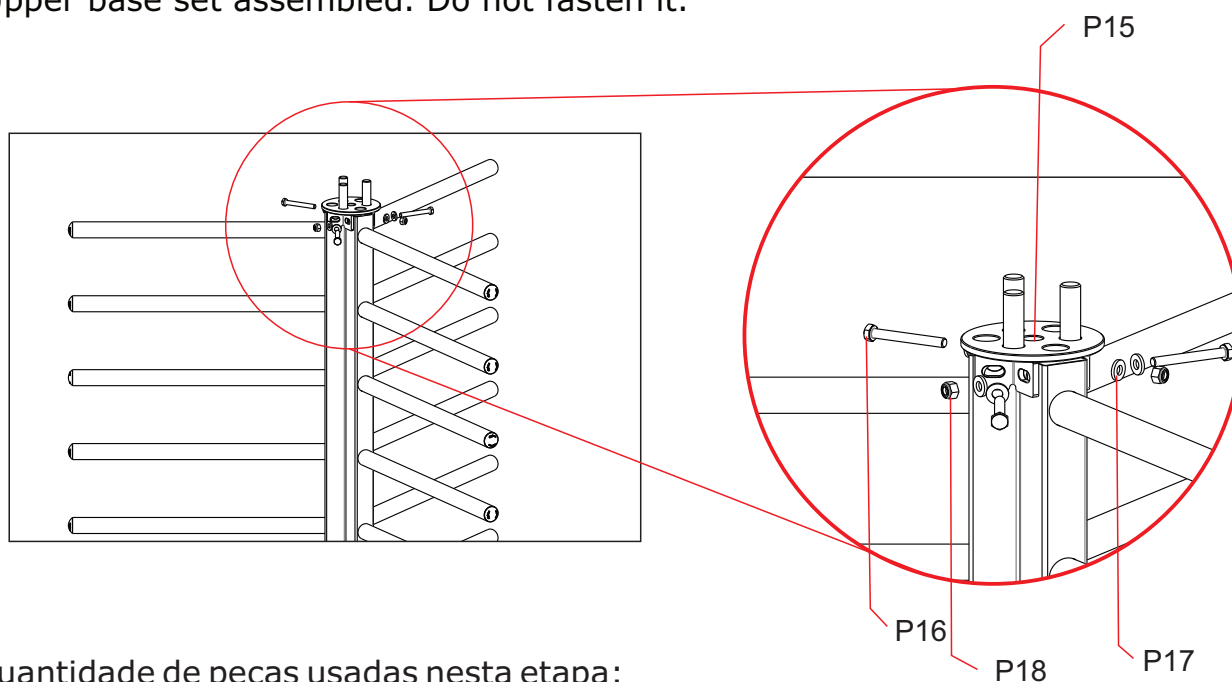

Quantidade de peças usadas nesta etapa:

- P9 = 2x - Triangle
- P10 = 3x - Central arm
- P11 = 6x - Allen screw M8 x 10
- P14 = 1x - Lower base
- P15 = 1x - Upper base
- P16 = 6x - Hexagonal head screw M10 x 80
- P17 = 12x - Washer D=22 x 10,5 x 3mm
- P18 = 6x - Nut M10

This assembly will result in the set (P28) – Central arms

5th Step: Fixing the bearing support

- Replace the fastener's washer (P21) for the washer (P7);
- Use the fastener (21); does not accompany the product;
- Place silicone rubber under the bearing; then fix the bearing support (P19) to the central hole, as shown in the image.

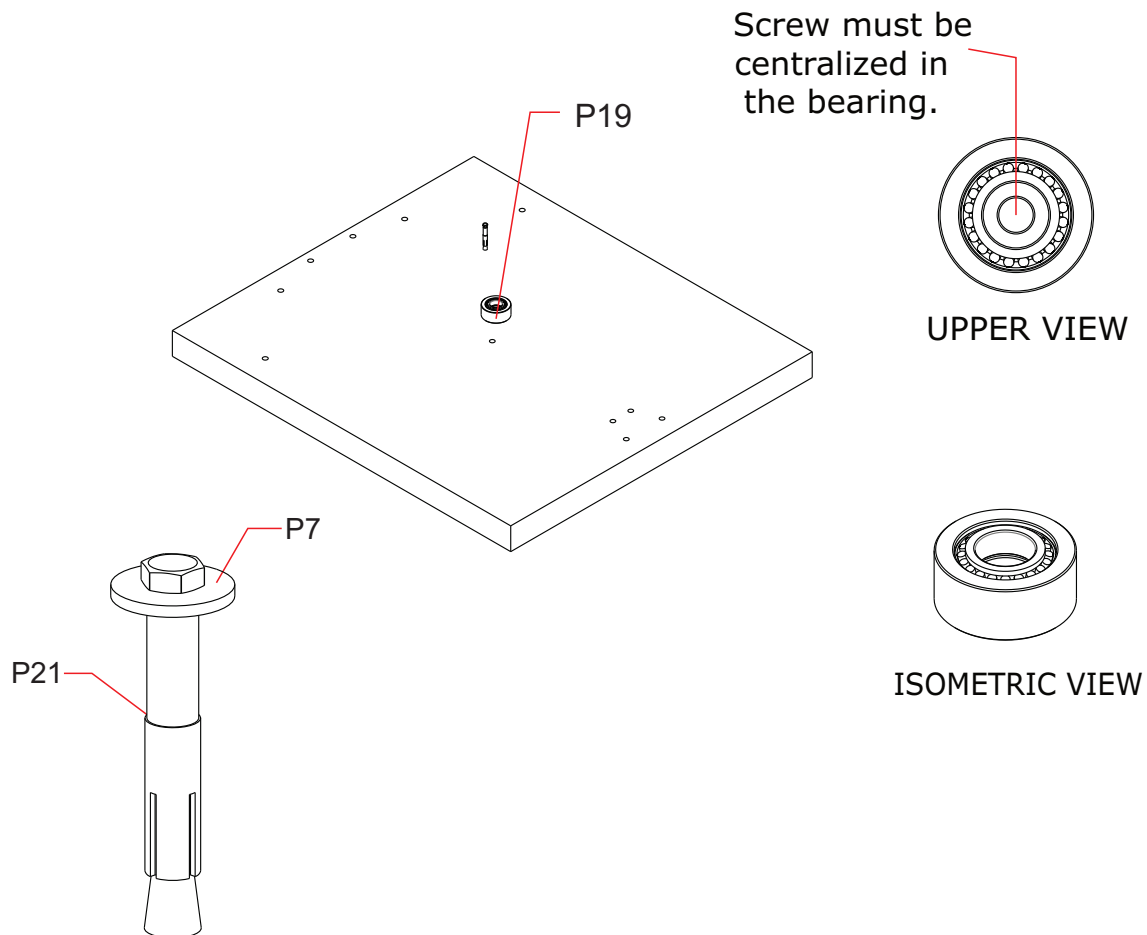

Quantity of parts used in this stage:

- P7 = 1x - Washer D= 30,5 x 10,5 x 9mm
- P19 = 1x - Bering
- P21 = 1x - Fastener



INFORMATION:

- Add more Molykote grease to the bearing since the grease sent is for transport only.
- Repeat the operation above in the both rotating centers.

6th Step: Fixing the sides

Fixing the sides with rods:

- a. Set the coincident flanges (P22) in the holes of the floor;
- b. Align the assembly of the sides with grid (P23) over the flanges, coinciding with the holes;
- c. Replace the fastener's washer (P21) by the washer (P7);
- d. Place the fasteners (P21) in all fixing points;
- e. Level the rod and wedge the base with washers, if correction is necessary;
- f. Fasten all the screws.

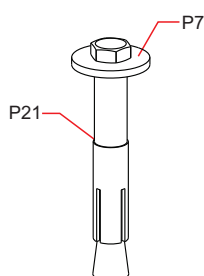

Quantity of parts used in this stage:

- P7 = 6x - Washer D=30,5 x 10,5 x 3mm
- P21 = 6x - Fastener
- P22 = 6x - Flange
- P23 = 1x (Assembly obtained in step 3) -
- Assembly of arch's sides

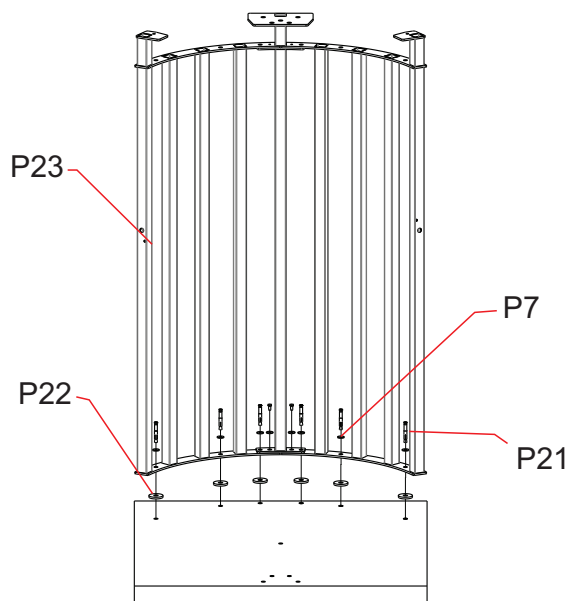

Fixing glass sides:

- a. Align the assembly of the sides to the glasses (P48), coinciding with the holes;
- b. Place the fasteners (P21) in all fixing points;
- c. Level the rod and wedge the base with washers, if correction is necessary;
- d. Fasten all the screws.

Quantity of parts used in this stage:

- P21 = 6x -Fasteners
- P48 = 1x - Assembly of sides to the glasses

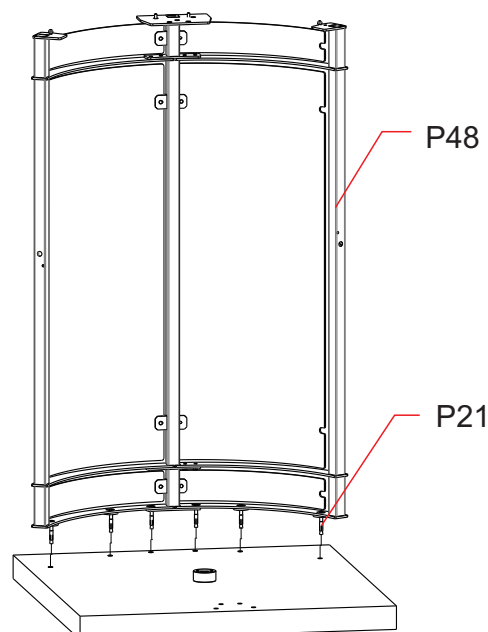

7th Step: Fixing the stationery arm

- a. Set the coincident flanges (P22) in the holes of the floor.
- b. Set the stationery arm (P24) over the flanges and coinciding holes;
- c. Replace the fastener's washer (P21) by the washer (P7);
- d. Place the fasteners (P21) in all fixing points;
- e. Level the rod and wedge the base with washers, if correction is necessary;
- f. Fasten all the screws.
- e. Level the column and wedge it with washers, if necessary;

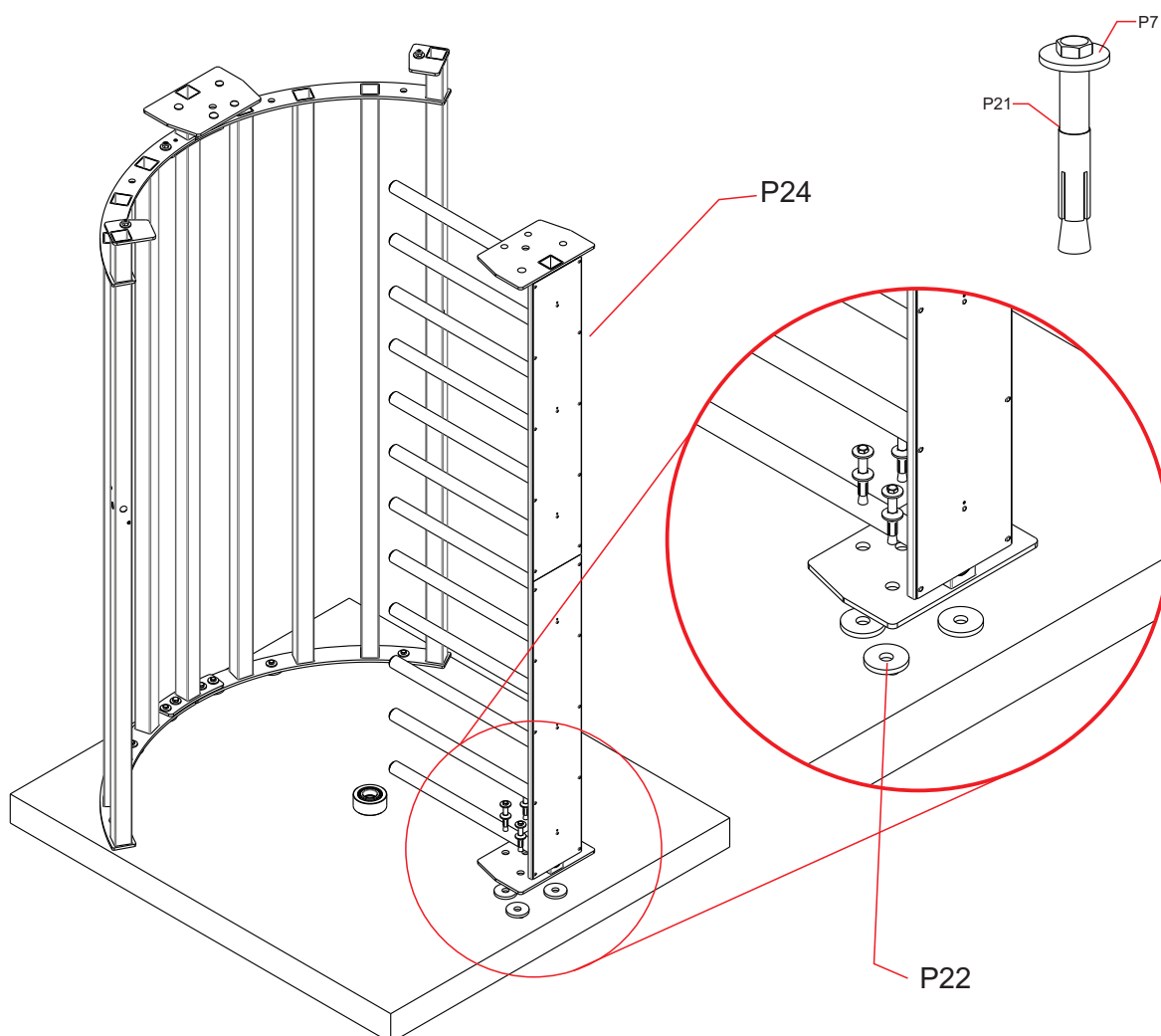

Quantity of parts used in this stage:

- P7 = 4x - Washer D=30,5 x 10,5 x 3mm
- P21 = 4x - fastener
- P22 = 4x - Flange
- P24 = 1x - Stationery arm

8th Step: Fixing the roof

- a. Place the roof over the side (P23 or P48);
 - b. Screw only the edges of the roof, using in each fixation 2 washers (P7), screw (P26), and nut (P18). The center will be fastened later, alongside the coverage.
- Obs.: Place the screw from the bottom upwards.

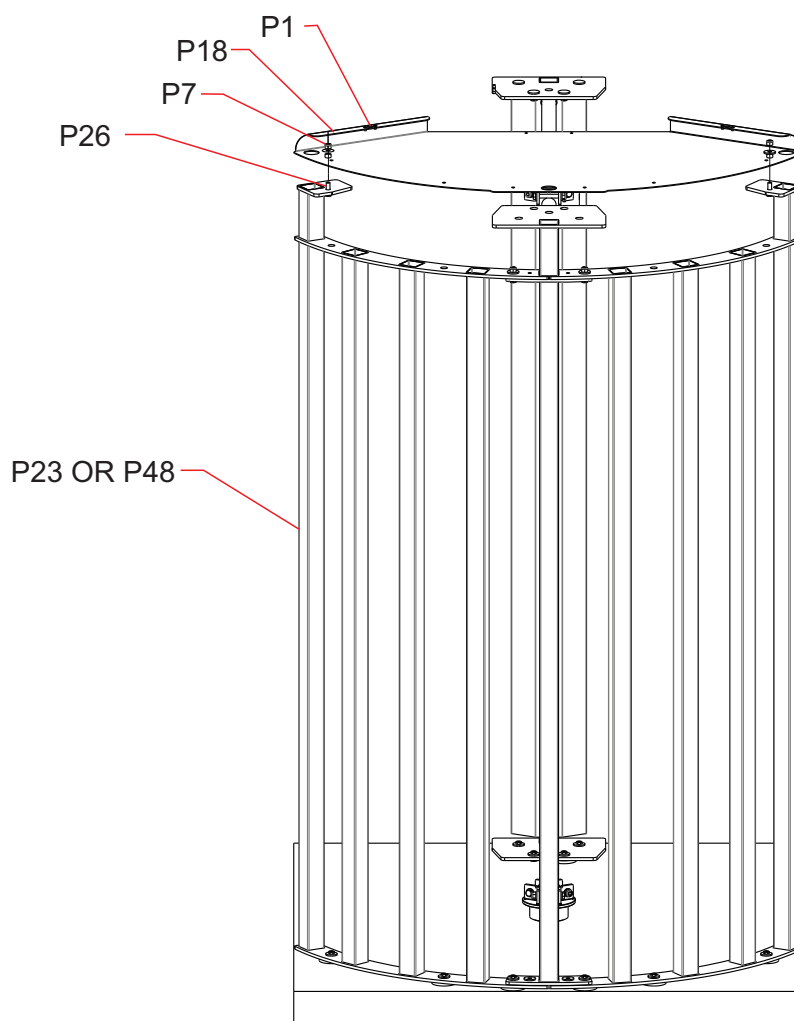

Quantity of parts used in this stage:

- P1 = 1x - Roof
- P7 = 4x - Washer D=30,5 x 10,5 x 3mm
- P18 = 2x - nut M10
- P26 = 2x - Hexagonal head screw M10 x 30
- P23 = Side assemble with rods
- P48 = Side assemble for glass

9th Step: Fixing the coverage

- a.** Check the height from the floor to the upper part of the roof (P1) – 2.1 meters with tolerance of 5mm;
- b.** Place the turnstile coverage (P27) over the roof (P1) and the stationery arm (P24);
- c.** In each fixation, use 2 washers (P7), screw (P26), and nut (P18). Obs.: place the screw from the bottom upwards. Do not fasten it.
- d.** Fix the roof (P1) with the turnstile coverage (P27), using screw (P3) and nut (P4);
- e.** Align the turnstile coverage (P27) with the central hole, considering 70cm plus the hole radius of 11.5cm = total 81,5 cm of the inner central rod of the structure to the hole's larger size and the inner stationery column in relation to the hole's large side. Details in the figure below:
- f.** After aligning, fasten the screws in all the fixing points of the turnstile coverage (P27).

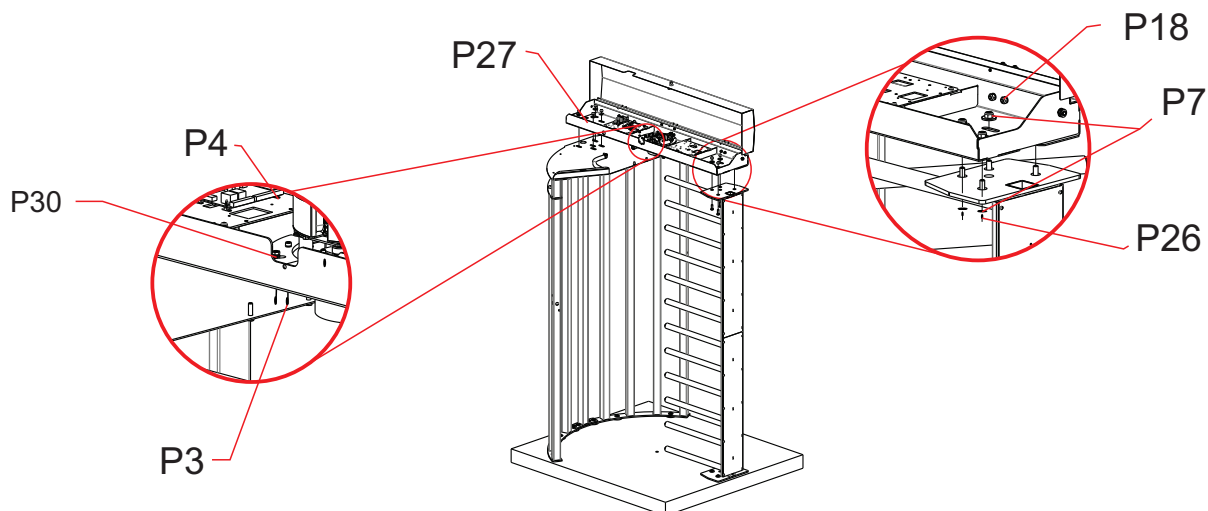

Alignment detail

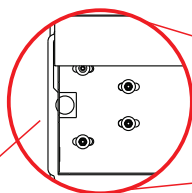

Coverage face must be parallel to the roof's side

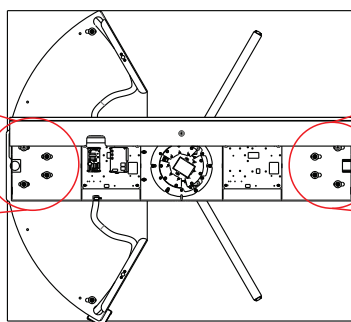

Alignment detail

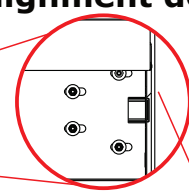

Coverage face must be aligned to stationery arm

Quantity of parts used in this stage:

- P3 = 2x - Allen screw M6 x 15
- P4 = 2x - Nut M6
- P7 = 16x - Washer D = 30,5 x 10,5 x 3mm
- P18 = 8x - Nut M10
- P26 = 8x - Hexagonal head screw M10 x 30
- P27 = 1x - Coverage
- P30 = 2X - Plat washer D= 6

10th Step: Fit the central pivoting arm

- a. Grease the bearing support (P19). (We recommend Molykote BR-2 Plus grease);
- b. Fit the central arms assembly (P28) in the bearing support (P19). In this stage, the assembler or mechanic cannot drop the central arms assembly, so we suggest an auxiliary assembler or to tie the central arm to the structure;
- c. Align one of the line of arms to the stationery arms, as shown in the image:

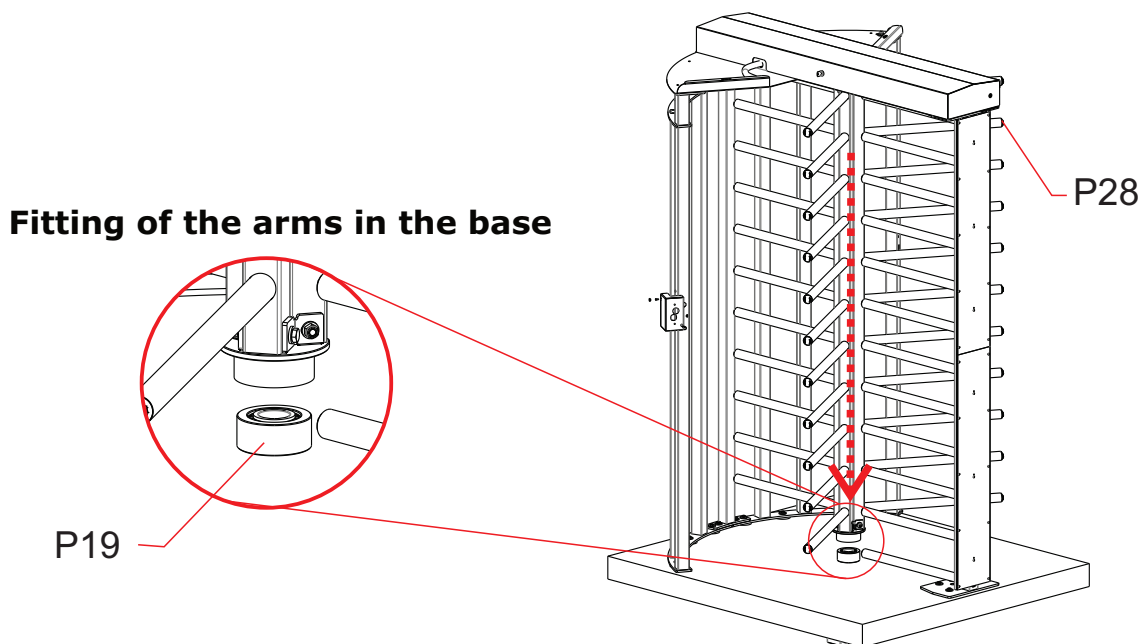

Position of the pivoting arm in the structure.

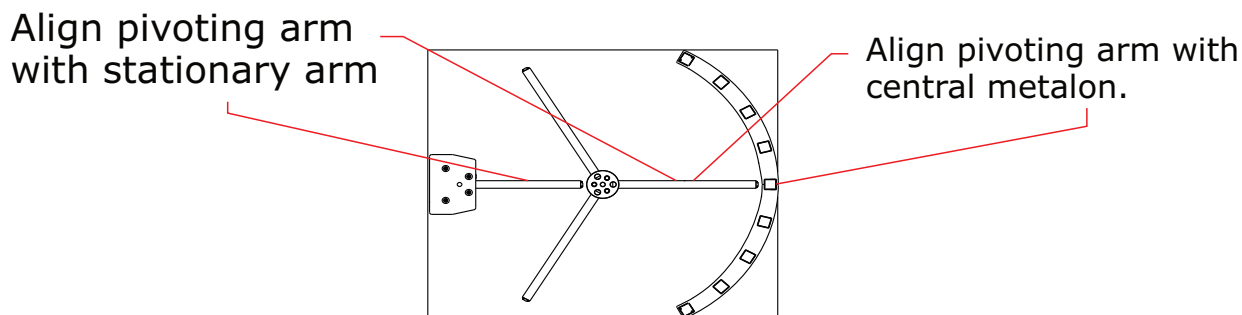

This must be the pivoting arm's position to fit the locking system detailed in the next step.

Quantity of parts used in this stage:

- P28 = 1cj (Assembly obtained in the 4th step of this Manual) – Central arm

11th Step: Fitting of locking system

- a. Fit the locking system (P29) in the pivoting arm assembly (P28), maintaining the arms' alignment, as seen in the 10th step; fit it in the coverage (P27);
- b. Fit the locking system (P29) with washer (P30), spring washer (P31), and nut (P32). 6 fixings;
- c. After the locking system (P29) is fixed (and only then), rotate the pivoting arm several times to settle the bearing supports and fasten all the screws in the pivoting arm assembly (P28).

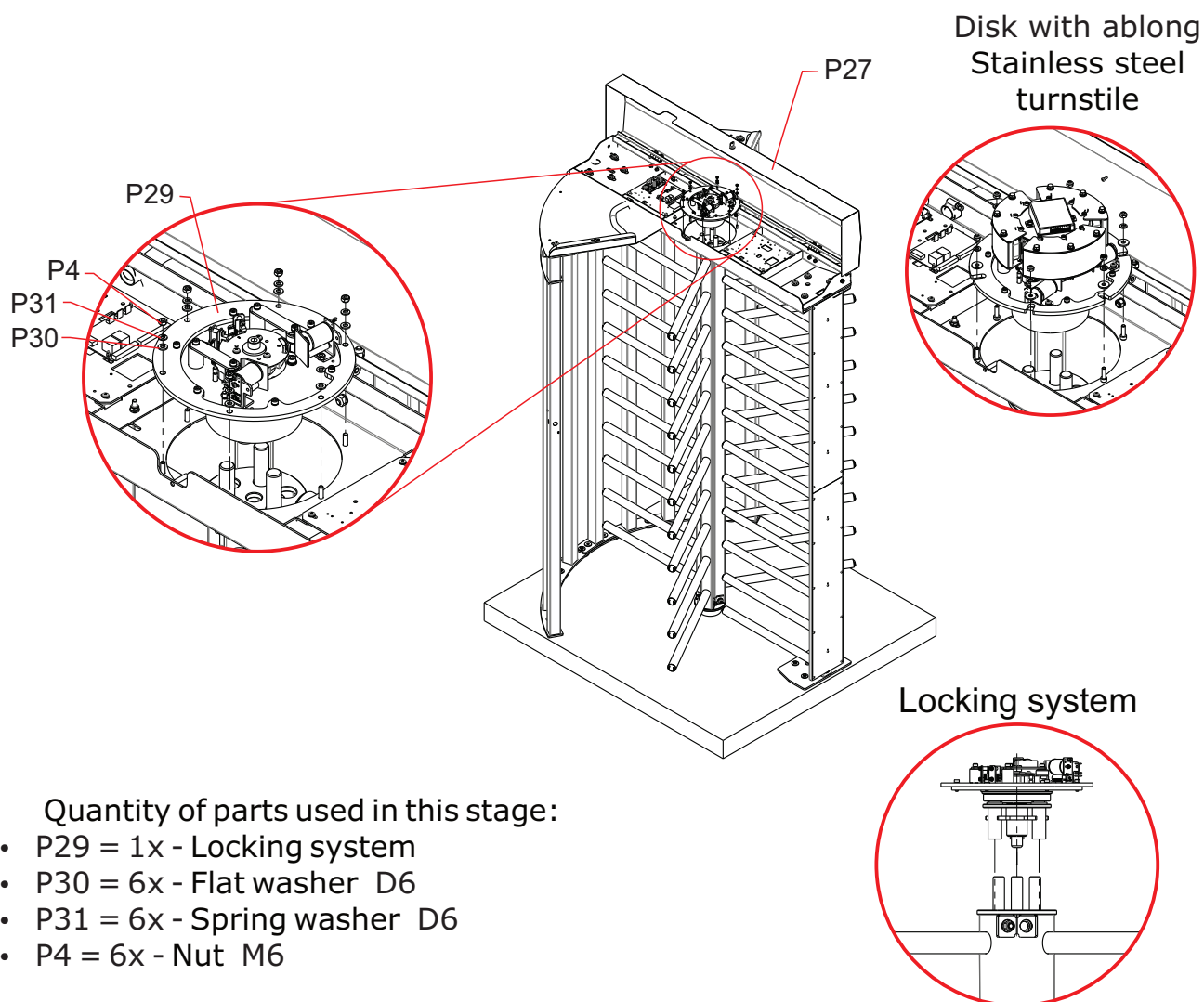

12th Step: Cable passage;

- a. Pass the power and network cables through a hose (P33);
- b. Put one of the hose's ends (P33) inside the coverage (P27) and the other end inside the side structure (P23 or P48);
- c. Inside the coverage (P27), place the clamp (P34) on the hose's end (P33) to avoid it being torn;
- d. Repeat the procedure above on both sides (entrance and exit) of the turnstile.

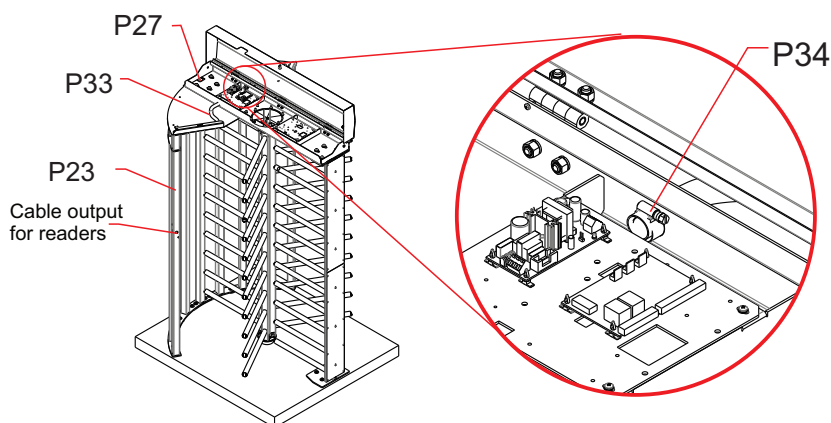

Quantity of parts used in this stage:

- P33 = 2x - Hose
- P34 = 2x - Clamp

13th Step: Assembling the card reader bracket

- a. Fix the card reader bracket (P35) with a screw (P36); repeat on both sides;
- b. Place the cowl cover (P37) in all holes, 4x in each bracket;
- c. Place the arms cover (P38) in the arms assembly (P28).

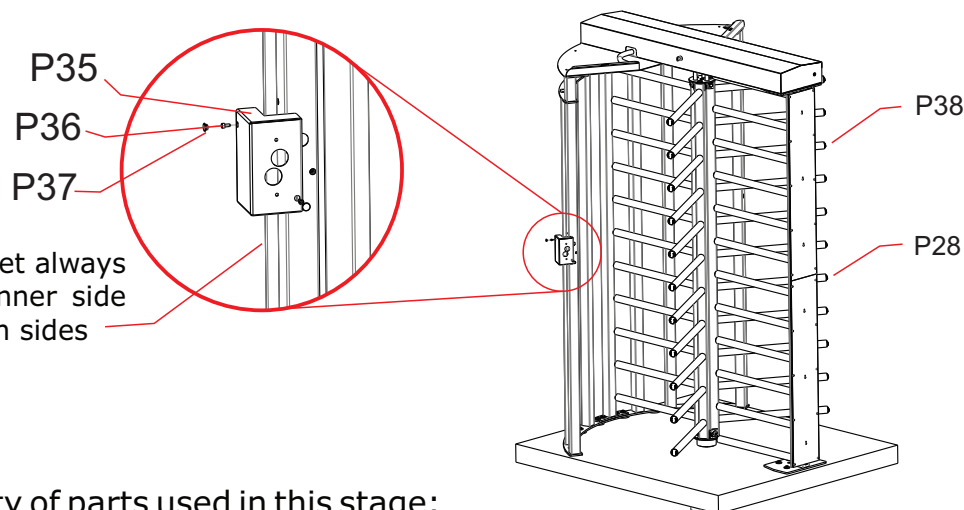

The holes of the bracket always have to stay in the inner side of the turnstile on both sides

Quantity of parts used in this stage:

- P35= 2x - Reader bracket
- P36= 4x - Allen screw M4x12mm
- P37= 8x Cowl cover

14th Step: Assembling sides glasses

a. Place the glass (P49) and fix it using washers (P44) 2x, the glass fixing bracket (P43), and screw (P46).

b. Place the glass (P50) and fix it using washers (P44) 2x, the glass fixing bracket (P43), and screw (P46).

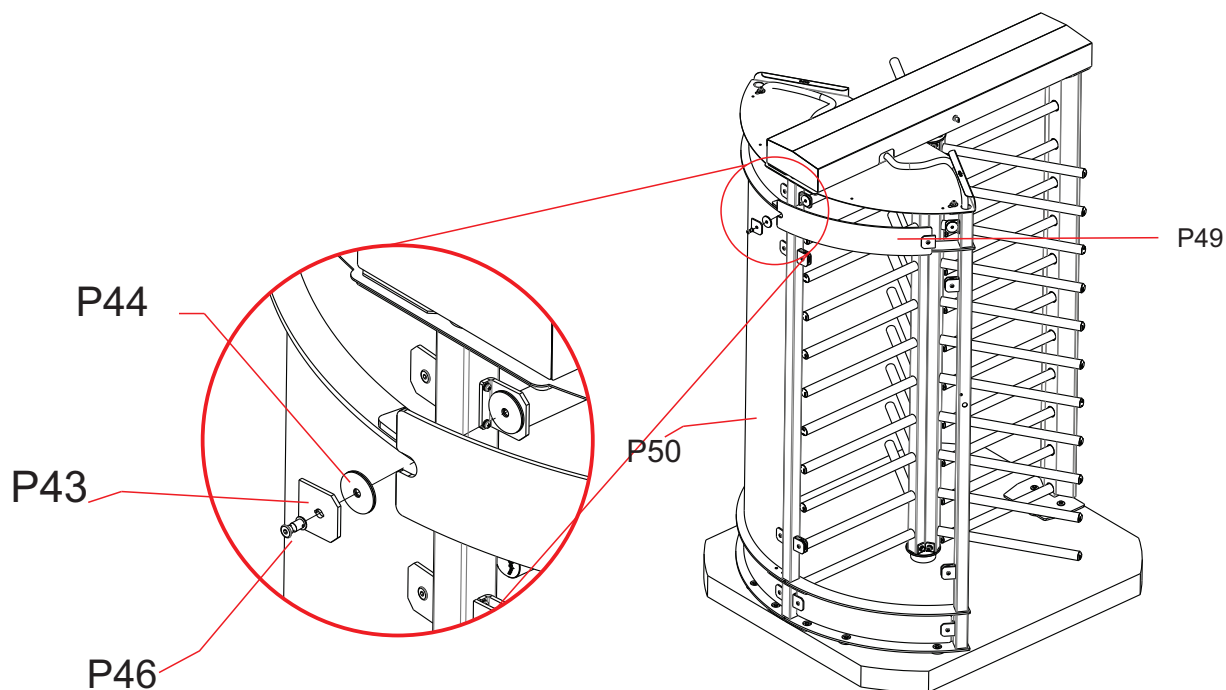

Quantity of parts used in this stage:

- P43 = 16x - Glass bracket
- P44 = 32x - PVC washer
- P46 = 16x -Fixing screw
- P49 = 4x - Smaller glass arch
- P50 = 2x - Larger glass arch

15th Step: Assembled Turnstile

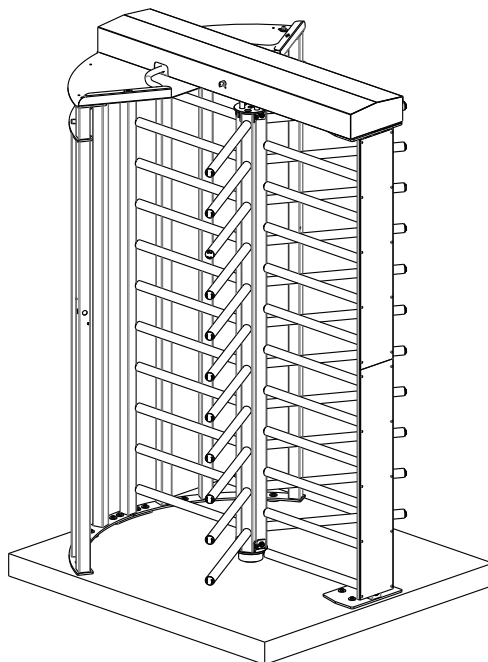

Turnstile with grid sides (gray, blue, and stainless steel)

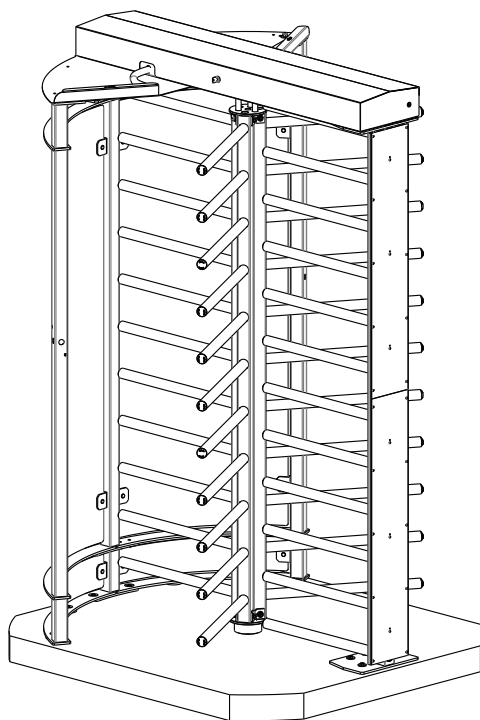

Turnstile with glass sides (gray, blue, and stainless steel)

5. Legenda

Descrição das Peças	CZ	AZ	IX	VDR	Observações
P1 - Turnstile's roof -	01	01	01	01	
P2 - Device for drilling -	01	01	01	01	Por Pedido
P3 - Stainless steel Allen M6x15 screw -	02	02	02	02	
P4 - Self-locking Hexagonal nut M6 -	08	08	08	08	
P5 - 5 rods turnstile side -	01	01	01		
P6 - 4 rods turnstile side -	01	01	01		
P7 - washer D=30,5x10,5x3mm -	39	39	39	29	
P8 - Stainless steel hexagonal head screw M10x20-	04	04	04	04	
P9 - Inner triangle -	02	02	02	02	
P10 - Central column arm -	03	03	03	03	
P11 - Stainless steel Allen M8x10 screw -	06	06	06	06	
P14 - Central column lower base set -	01	01	01	01	
P15 - Central column upper base set -	01	01	01	01	
P16 - Stainless steel hexagonal head screw M10x80-	06	06	06	06	
P17 - Washer D=22x10,5x3mm -	12	12	12	12	
P18 - Self-locking Hexagonal nut M10 -	18	18	18	18	
P19 - Lower bearing set -	01	01	01	01	
P20 - Stainless steel cross head M4x12 screw -				32	
P21 - Fastener (C38312 3,1-2-3-8) -	11	11	11	11	Not provided
P22 - Turnstile lower Flange -	10	10	10	04	
P23 - Sides with grid assembly	01	01	01		3 rd step
P24 - Stationery arm set -	01	01	01	01	
P25 - Stainless steel flat washer D4 -				32	
P26 - Stainless steel hexagonal head M10x30 -	12	12	12	12	
P27 - Turnstile coverage -	01	01	01	01	
P28 - Central arms -	01	01	01	01	4 th step
P29 - Turnstile's locking system set -	01	01	01	01	
P30 - Stainless steel flat washer D6 -	06	06	06	06	
P31 - Stainless steel spring washer D6 -	08	08	08	08	
P33 - Flexible hose -	02	02	02	02	1m each
P34 - Clamp -	02	02	02	02	
P35 - Card reader bracket -	02	02	02	02	
P36 - Stainless steel Allen M4x8 screw -	04	04	04	04	
P37 - Cowl cover -	08	08	08	08	

Descrição das Peças	CZ	AZ	IX	VDR	Observações
P38 – finishing cover -	06	06	06	06	
P39 - 2 rods turnstile side -				01	
P40 - 1 rod turnstile side -				01	
P41 – stainless steel flat washer D10 -				04	
P42 – glass stationery bracket -				16	
P43 – glass fixing bracket -				16	
P44 – PVC washer -				64	
P45 - Nut for glass bracket -				16	
P46 – screw for glass bracket -				16	
P48 – side assembly for glasses -				01	3 rd step
P49 – smaller glass arch -				04	
P50 – larger glass arch -				02	

Caption of table above:

GRAY – grayturnstile

BLUE – blue turnstile

S. STEEL – stainless steel turnstile

GLASS – turnstile with glass sides (it can be done in the colors gray, blue, and stainless steel)

6. Power supply

This power supply was especially designed for the line CATRAX. Among the main advantages of this optional item, is its adaptation capability to the voltage variations often found in installation sites – the input voltage can vary between 100 and 240 Vac.

The supply's specific technical features, protections and dimensions were carefully tested and approved in hostile temperature and environmental conditions, which ensures the adequate power supply to the equipment's performance. Besides the input and output voltages indicated in the image below, the supply has a short-circuit and overheating protection.

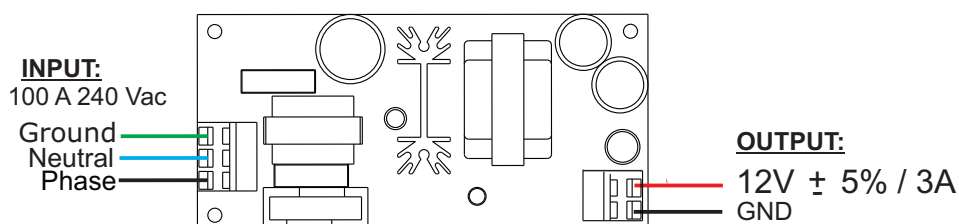

TIP: The power supply can be mounted to the board's support hat accompanies the Turnstile.

7. Control board

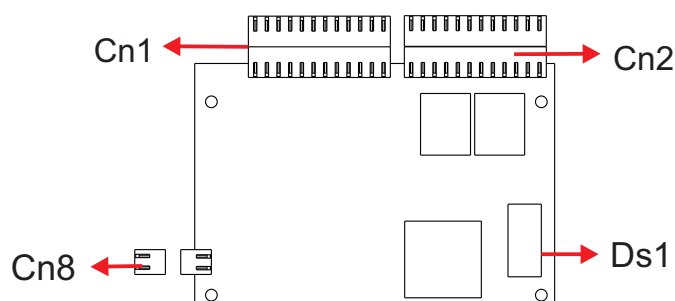

Turnstile Tx1500's control board was designed to meet most technologies of access control terminals in the market. The controller have mechanical features and layout perfectly suited for the Turnstile Tx1500's needs and it is one of the best options for the equipment's operation.

The following images show the control board with its straps, connectors, and dipswitch, as well as the location of the power supply and the control board.

The table below describes the functions of the control board's connectors:

<u>Signal</u>	<u>Name/Description</u>
CN1	INPUTS
1	+Vext1 (enables turn through voltage)
2	HAB1 (enables turn through dry contact – from right to left)
3	GND
4	Vext2 (enables turn through voltage)
5	HAB2 (enables turn through dry contact – from left to right)
6	GND
7	+12Vdc (available to auxiliary – maximum 500 mA)
8	CLOCK1 (input for reader from left to right)
9	DATA1 (input for reader from left to right)
10	CLOCK2 (input for reader from right to left)
11	DATA2 (input for reader from right to left)
12	GND
13	PROG1 (programs direction)
14	PROG2 (programs direction)
15	PIC1 (controls frontal pictogram 1)
16	PIC2 (controls frontal pictogram 2)
CN2	OUTPUTS
1	NO or NC Contact (HAB1 return)
2	Contact C (HAB1 return)
3	NO or NC Contact (HAB2 return)
4	Contact C (HAB2 return)
5	Output for indicative X (open collector NPN – maximum 500 mA) orange wire
6	Output for arrow > (open collector NPN – maximum 500 mA) blue wire
7	Output for arrow < (open collector NPN – maximum 500 mA) green wire
8	+12Vdc (indicative arrows' power) red wire
9	GND (indicative arrows' power) black wire
10	+ solenoid of badge collector box
11	- solenoid of badge collector box
12	Sound signal (open collector – NPN)
CN3	SERIAL RS-485
1	DATE -
2	DATE +
3	GND
CN4	SIDE PICTOGRAM 2
1	+12Vdc (indicative arrows' power)
2	Output for indicative X (open collector NPN – maximum 500 mA)
3	Output for arrow > (open collector NPN – maximum 500 mA)
4	GND (indicative arrows' power)
CN5	SIDE PICTOGRAM 1
1	+12Vdc (indicative arrows' power)
2	Output for indicative red arrow (open collector NPN – maximum 500 mA)
3	Output for green arrow (open collector NPN – maximum 500 mA)
4	GND (indicative arrows' supply)
CN6	INPUT/OUTPUTS
1	input or output 1 – configure at S4 (IN or OUT)
2	input or output 2 - configure at S5 (IN or OUT)
3	GND
4	+12Vdc
CN7	SERIAL RS-232
2	TX
3	RX
5	GND
CN8	POWER – POWER INPUT
1	+12Vdc power input
2	GND power input
CN9	BOX SENSOR
1	LED anode
2	box signal
3	GND
4	GND
CN10	ELECTROMAGNETS
1	+ electromagnet 1
2	- electromagnet 1
3	+ electromagnet 2
4	- electromagnet 2
CN11	OPTICAL SENSORS
1	sensor 1 signal
2	LED 1 anode
3	sensor 2 signal
4	GND
5	LED2 anode



INFORMATION:

- Side pictogram 1 and 2 refer to the devices located on top of the equipment.
- The cables of the optical sensors (CN11) and the electromagnets (CN10) are provided alongside Tx1500.
- The cable of the box sensor (CN9) is provided alongside the collecting box kit (optional).

Particularly about the CN11 connector, pins 13 and 14: Turnstile Tx1500 can be configured as follows to determine direction passage:

Passage direction	PROG1 (pin 13)	PROG2 (pin 14)
Free in both directions	Open	Open
Controlled from left to right	GND	Open
Controlled right to left	Open	GND
Controlled on both sides	GND	GND

Pins 15 and 16, which control the side pictograms, must be configured thusly:

PIC1 (pin 15)	PIC2 (pin 16)	Pictogram 1	Pictogram 2
Open	Open	Green arrow	Green arrow
Open	GND	Green arrow	Red arrow
GND	Open	Red arrow	Green arrow
GND	GND	Red arrow	Red arrow



INFORMATION: PIC1 and PIC2 refer to the pictograms located on each side of the equipment.

The following sections concern important aspects of the control board configuration and connections of Tx1500.

7.1 Inputs

The input signals or passage clearance (HAB1 and HAB2) can be originated by a relay contact, pushbutton contact, tension from 5 to 24 Vac/dc, from 110 to 220 Vac/dc. To enable passage t

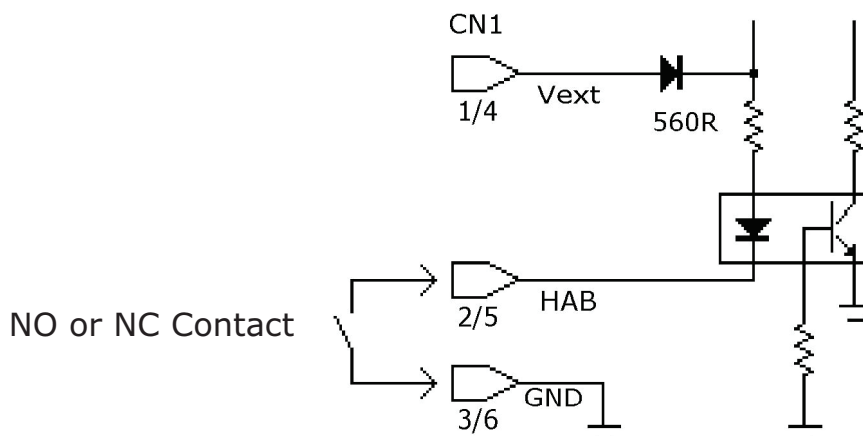

Enabling passage through tension pulse is shown in the image below. It is necessary to observe the polarity of the Vdc voltages and to use an external resistor for high voltages (110V and 220V)

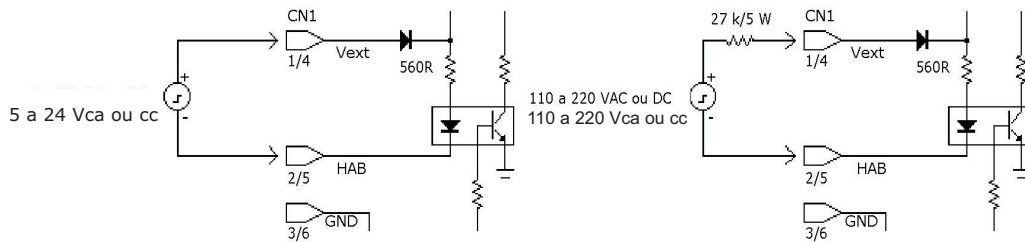

The control board also has inputs for optical sensors (CN11) that monitor rotation without mechanical wear, and two opto-isolated inputs to clear the Turnstile Tx1500 if required.

7.2 Outputs

Turnstile Tx1500 board has outputs for return signals, electromagnets, pictogram, collecting box, and sound alarm.

• **Return signals**

Return signals indicate the moment and direction of passage and are originated at the relay – normally open contact (NO) or normally closed contact (NC). Connect the outputs according to the image below:

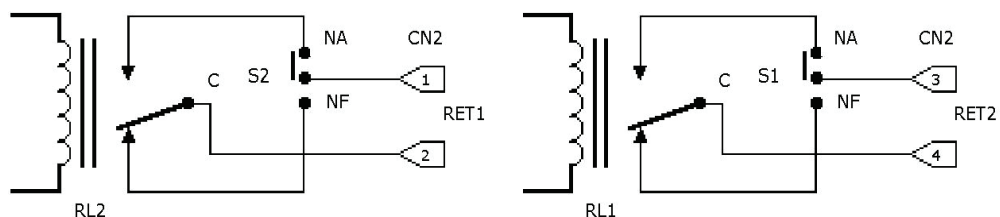

• **Electromagnets**

Electromagnets are activated for blocking the turnstile. Opposite to the traditional solenoids, electromagnets do not cause abrasion between the coil and the locking device, avoiding malfunctions. Moreover, the activation is done through a transistor, and not a relay, avoiding the electromagnet to be blown due to the “contact welding” (there is no mechanical wear).

• **Sound alarm**

The sound alarm output is activated by a NPN transistor (maximum 500 mA) every time that Turnstile Tx1500:

- Receives a clearance signal (two short rings)
- Is not cleared and is forced during 1 second (1-second ri

Connect the outputs according to the following image:

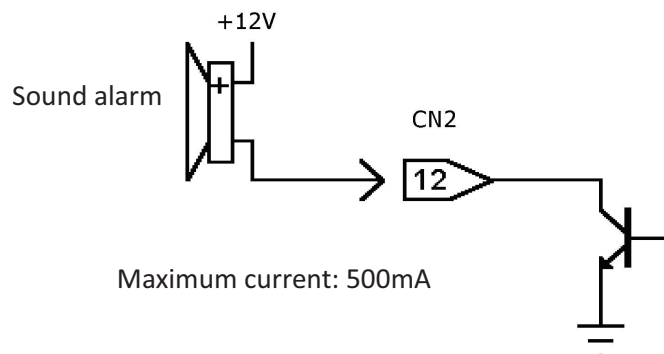

7.3 Configuration of control board – Switch Ds1

The switch (or dipswitch) DS1 allows programming the following actions:

- passage direction
- Maximum time for turns
- NO inputs (relay or pushbutton contact normally open and without input voltage), enabling passage in face of these signals; or NC inputs (relay or pushbutton contact usually closed and with input voltage), enabling passage in the absence of these signals.
- enabling of a signal for a sound alarm if the access control remains at mid turn for more than 5 seconds.

To program DS1, put each pin in the desired position, according to the table below.

	01	02	03	04	05	06	07	08
Cleared in both directions	-	-	-	OFF	OFF	-	-	-
Blocked from left to right	-	-	-	ON	OFF	-	-	-
Blocked form right to left	-	-	-	OFF	ON	-	-	-
Blocked in both directions	-	-	-	ON	ON	-	-	-
NO inputs	-	ON	-	-	-	-	-	-
NC inputs	-	OFF	-	-	-	-	-	-
Enables sound signal	ON	-	-	-	-	-	-	-
Disables sound signal	OFF	-	-	-	-	-	-	-
Enables sound signal in mid-turn	-	-	-	-	-	ON	-	-
Disables sound signal in mid-turn	-	-	-	-	-	OFF	-	-
Wait until first turn	-	-	-	-	-	-	ON	ON
Wait for 5 seconds	-	-	-	-	-	-	OFF	ON
Wait for 10 seconds	-	-	-	-	-	-	ON	OFF
Wait for 15 seconds	-	-	-	-	-	-	OFF	OFF
Habilitation per border*	-	-	OFF	-	-	-	-	-
Habilitation per level**	-	-	ON	-	-	-	-	-

* "Habilitation per border" means that Tx1500 will be enabled by a pulse at the entry border (NC inputs) or exit border (NO inputs).

** "Habilitation per level" means that Tx1500 will remain free as long as there is an input signal.

7.4. Examples of configurations

1 - To receive a relay pulse (NO contact), clear the turning and wait to turn for 10 seconds:

	1	2	3	4	5	6	7	8
Configuration	-	ON	OFF	ON	ON	-	ON	OFF

2 - To leave the clockwise direction always cleared and, when the HAB2 (anti-clockwise) clearance signal is received, clear passage for undetermined period:

	1	2	3	4	5	6	7	8
Configuration	-	ON	OFF	OFF	ON	-	ON	ON

3 - To clear the turning while the relay has the contact closed and, as soon as the relay contact is open, remove clearance:

	1	2	3	4	5	6	7	8
Configuration	-	ON	ON	ON	ON	-	ON	ON

7.5. Serial communication

Turnstile Tx1500 Duo's control board allows serial configuration of the equipment. The communication protocol used is as follows:

STX	Tamanho(LSB)	Tamanho(MSB)	Comandos	BCC
-----	--------------	--------------	----------	-----

Where:

- STX represents beginning of transmission (0x02)
- Size(LSB) is the byte with the least significant size component
- Size(MSB) is the byte with the most significant size component
- Commands is the information sent to the equipment (one or two bytes);
- BCC is the XOR operation for all bytes sent, from STX to Commands



ATTENTION:

- Size corresponds to the number of bytes sent (total command bytes: 1).
- The protocol communication rate is 115,200 bps.

The following table shows the enabling commands that can be sent to Turnstile Tx1500 Duo:

HEXA	ASCII	FUNCTION
0x48	H	Clears direction from right to left
0x41	A	Clears direction from left to right
0x44	D	Clears both directions
0x43	C	Back to controlling (command used to leave free state)
0x4C	L	Turnstile free (include free direction <0x4C> + <0x48>)
0x53	S	Direction programming (include direction to be programmed <0x53> + <0x48>)

The following table shows the return commands that can be sent by the equipment:

HEXA	ASCII	FUNCTION
0x48	H	free from right to left
0x06	▲	ACK, indicates command OK
0x15	§	NACK, indicates invalid command
0x1A	→	Return command from right to left (RET1)
0x1B	←	Return command from left to right (RET2)

The following table shows some examples of command:

Free from left to right (1 passage):

0x02	0x02	0x00	0x48	0x48
------	------	------	------	------

Configure from left to right as always free:

0x02	0x03	0x00	0x4C	0x48	0x05
------	------	------	------	------	------

Return OK command:

0x02	0x02	0x00	0x06	0x06
------	------	------	------	------

8. Dimensions

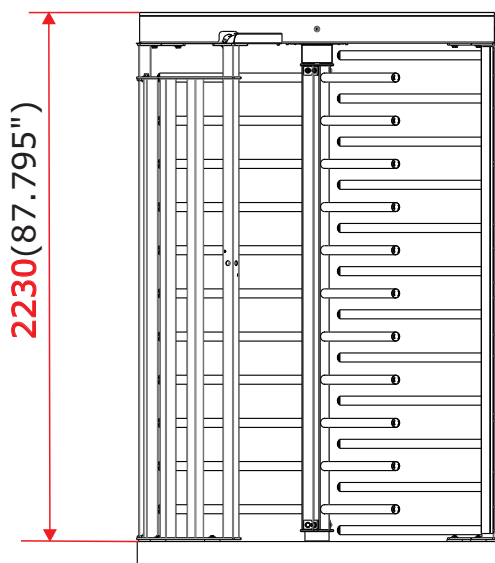

Closed cover

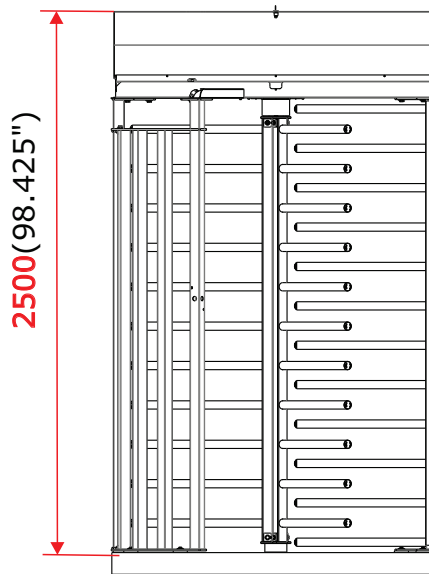

Open cover

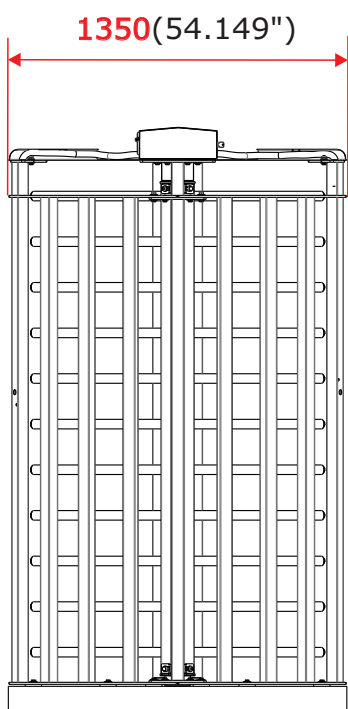

Side view

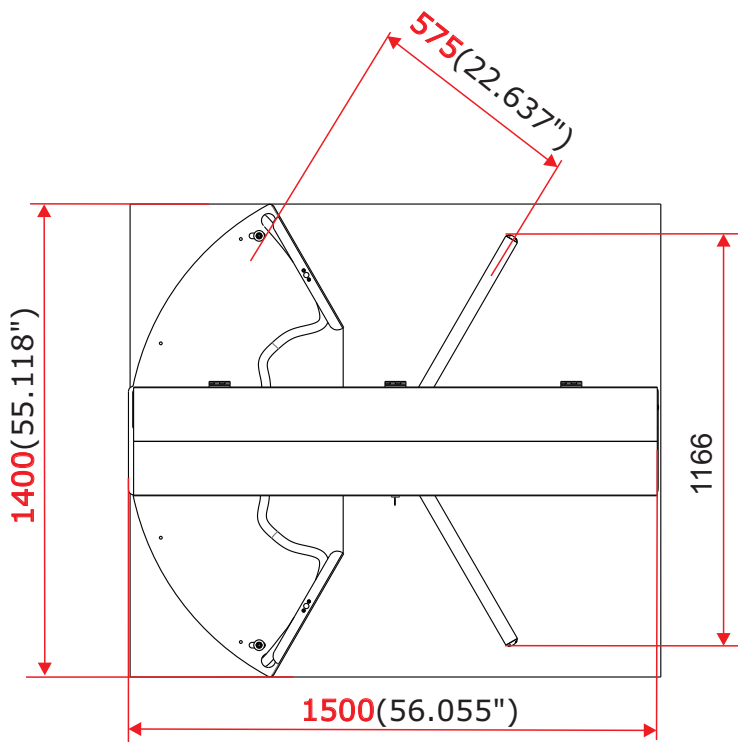

Upper view



INFORMATION: All measures presented in the images are in millimeters(Inches).

9. Warranty and technical assistance

Digicon is responsible for the project, skilled labor, and quality of the materials used in the manufacturing of our products, ensuring that the equipment and all parts are free of manufacturing defects or problems. Digicon commits itself to replace or repair, as we choose, any part or equipment presenting manufacturing defects without any costs to the buyer, in our factory in Gravataí or our branch office in São Paulo, in the conditions set below:

1. The buyer is responsible for the costs of shipping (return service) of the product to the factory in Gravataí or the branch office in São Paulo.
2. The warranty period is counted from the date of emission of the bill of sale and encompasses:
 - a) 12 (twelve) months for equipment, accessories, parts, and pieces, including the legal warranty period of 90 (ninety) days.

Legal warranty

The customer has the period of 90 (ninety) days, from the date of emission of the bill of sale, to complain about apparent defects (easily observable in the product), such as the items that constitute the product's exterior and any other area accessible to the user, just like appearance parts and general accessories.

- b) 90 (ninety) days for repairs or technical assistance

3. Warranty shall be granted to the buyer only in the face of the bill of sale (original or copy)

4. Warranty does not apply in the following cases or conditions:

- a) defects and damages caused by accidents, negligence, or reasons of force majeure
- b) defects and damages caused by inappropriate storage or lack of prolonged use
- c) defects and damages caused by improper use of the equipment
- d) defects and damages caused by improper operation or installation of the equipment
- e) vandalism
- f) natural impacts (lightning, flooding, etc.)
- g) defects and damages caused by abnormal temperature conditions, voltage/frequency, or humidity out of the levels specified in the installation and operation manual, once proven
- h) reconditioning, chrome plating, nickel plating, and painting

5. Warranty shall be automatically canceled for equipment that:

- a) suffers modifications, adaptations, or any alterations performed by the client or by third parties without Digicon's written consent
- b) goes through maintenance or repairs by people not authorized by Digicon
- c) suffers alteration of serial number or violation of the identification label
- d) is not paid for in the conditions, amounts, and deadlines described in the bill of sale

6. Digicon is not responsible for eventual losses suffered by the down time of the equipment

7. The repair of a warranted product will be performed inside the Digicon facilities.

digicon

**Headquarters/RS
Factory, Technical Assistance and Sales**

Address: Rua Nissin Castiel, 640 - Distrito Industrial.
Gravataí/RS CEP 94045-420
Sales: 55-51-3489-8700/ 3489-8745
Technical Assistance: 55-51-3489-8903
Fax: 55-51-3489-1026
Email: vendas.aceso@digicon.com.br

**Branch/ SP
Development, Technical Assistance and Sales**

Address: Rua São Paulo, 82 - Alphaville.
Barueri/SP CEP 06465-130
Phone: 55-11-3738-3500
Fax: 55-11-4191-2585
Email: vendas.aceso@digicon.com.br
Homepage: www.digicon.com.br

