

digicon

CE

Revision	Date	Reviser	History
07	29/APR/2020	<ul style="list-style-type: none">• Bruno Hayashi• Beal• Mário Arand	<ul style="list-style-type: none">• New manual layout;• Content update.

© Copyright– Digicon S.A.
Controle Eletrônico para Mecânica – 2020

*All rights reserved. No part of this publication may be reproduced, transmitted, transcribed, stored in a retrieval system, translated into any language or computer language in any electronic, magnetic, optical, chemical, manual way, or otherwise, without express written permission from **Digicon S.A.***

Code: 069.31.220
Revision 07

This manual was elaborated by: Digicon S.A. Controle Eletrônico para Mecânica
Documentation Sector - EDS



After the product's service life ends, dispose of it according to the National Solid Waste Policy.

Índice

1. Guidelines	06
2. Environmental issues	06
3. Additional manuals	06
4. Safety instructions	07
5. Introduction	09
6. Characteristics and operation	09
7. Models	11
8. Installation	14
8.1 Installation site	14
8.2 Package content	14
8.3 Accessing dFlow	15
8.4 Drilling and anchorage	16
8.5 Fixating and powering the sensor	19
8.6 Routing of interconnection cables	22
8.7 Power connection and external network	24
9. Powering the equipment	25
9.1 Important checks	25
9.2 Turning on the circuit breaker	27
10. Configuration via selector switch	27
11. Optional items	31
11.1 Card collector	31
11.2 Display	32
11.3 No break	32
11.4 Bar code reader	33
11.5 Access control module - MCA	33
11.5.1 Antennas	33
11.5.2 Biometrics	34
11.5.3 Bar code reader	34
12. Technical characteristics	35
12.1 Dimensions	37
12.2 Other information	38
13. Preventive maintenance	40
14. Cleaning	40
14.1 Maintenance and conservation of doors	40
14.2 Maintenance and conservation passage control sensor	40
14.3 Maintenance and conservation of dFlow (glasses and stainless steel sheets)..	40
15. Warranty and technical assistance	41

1. Guidelines

- Read the information carefully before using the product. This ensures the correct use of the equipment and maximum use of its technical features as well as prolonged service life.
- This product does not present sealing against rain, that is, it is designed to be used indoors.
- This product was not designed to be placed directly under sunlight.
- Keep this manual for future consultations.
- Digicon reserves its right to alter the characteristics of its products at any moment to adapt them to more recent technological advancements.
- Digicon maintains its right to alter the information contained in this manual without previous notice.
- Digicon does not provide any contractual warranty concerning the information in this manual and cannot be held responsible for errors it may contain and problems due to its use.
- The information contained in this manual is exclusive property of Digicon and is protected by copyright laws.
- This manual cannot be reproduced, photocopied or translated, in its entirety or in part, into any kind of medium, without Digicon's written consent.
- The equipment described here is customizable, that is, this manual describes all possible models and they may not reflect, necessarily, the model purchased by the customer.

2. Environmental issues

The materials used in the product packaging are easily separated (screws, bubble wrap, wood, cardboard), which makes disposing of the items more accessible.

The dFlow equipment has recyclable and/or reusable materials in its building. In case of exchange of parts or components, dispose of the parts with specialized services.

In case of disposal of equipment, make sure to follow the local valid regulations.

3. Additional manuals

Besides this manual, we offer other three documents:

- Integrator manual
- Support and maintenance manual
- Work plan manual

4. Safety Instructions

This manual has several safety messages: try to read and follow them in order to promote your safety and that of third parties.

- Applicable symbols:

	It indicates important instructions concerning operation or maintenance.
	It indicates a powered terminal where dangerous voltage may be present.
	It indicates a protective ground wire.

- Terminology:

The terms defined below are used in this document. The definitions are based on those found in safety regulations in order to direct tasks for a certain target audience.

Technical professional the term applies to trained or qualified people who have permission to install or replace technical equipment or to offer technical support. It is recommended that the technical professional use his experience and technical abilities to avoid possible injuries regarding himself and others due to the risks in areas of restricted access.

User and operator the terms user and operator apply to people who are not technical professionals.

- Informative

	<p>WARNING</p> <ul style="list-style-type: none"> - Electrical shock can cause serious personal injuries and even death; thus, avoid direct contact with dangerous voltages while handling the equipment. - Ground wiring is essential for safe operation: make sure the power network meets this requirement safely. - Only qualified technical professionals are allowed to install and perform maintenance in the equipment. - Before any maintenance, switch the circuit breaker off to stop the power into the equipment.
--	---

• General precautions:

Wristwatch and jewelry To avoid damages to the equipment and to the operator, do not wear objects that conduct electricity.

Atmospheric discharges –Do not work on this equipment during atmospheric discharges.



Labels– Do not remove warning labels. If the item is illegible or damaged, replace it by a new label.

Children– Do not leave unattended children near the equipment.

ESD– Electrostatic discharge.



- I. Keep the components inside the antistatic package until installation.
- II. Avoid touching the electronic components when installing a module or board.

	<p>WARNING Avoid electrical shock! Opening or removing the doors of this equipment can expose it to dangerous voltages.</p>
	<p>WARNING To reduce the risk of electric shock, before maintenance, turn off the power of the equipment by moving the circuit breaker key to the position OFF. Leave all maintenance services to qualified technical professionals.</p>

5. Introduction

When we combine innovation and robustness, design and reliability, we find the best access control solution. Digicon presents a solution developed to the last detail in order to offer a new concept to the market. From an intense research process on world tendencies and a comprehensive engineering work, dFlow is born.



6. Characteristics and operation

dFlow is the first access controller that perfectly fits into the Free Flow concept. This is a new way of conceiving access control because its doors remain normally open, while traditional equipment have barriers in the normally closed position. This paradigm shift is what differentiates it from a Free Flow currently available.



*NOTE- **dFlow** is a configurable equipment and can be provided with the option of closed doors.*

Even though it seems that equipment is always open, it has doors. They are activated only when one or more unauthorized people, including tailgating users, try to go through the equipment. The closing system is fast and progressive, performed by a set of the exclusive motor control, innovative sensing, and sophisticated algorithm. This results in a very pleasant and fast experience for authorized users and offers unprecedented levels of security for the establishment.



The technology developed in Brazil by Digicon detects, with high precision, users moving in any direction inside the equipment. Such precision originates in the innovative sensing system, which can be compared to an almost limitless amount of traditional infrared sensors, thus allowing the doors to remain open for authorized users and closed to non-authorized people.

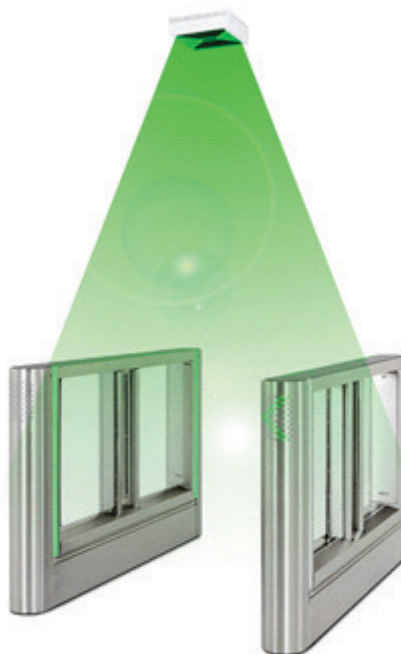

Luminous windows made of LED lights follow users during their path inside the equipment. They can have different colors for each user group. In a school, for example, students can belong to the green-colored group, educators to the yellow-colored group, and parents to the blue-colored group. Users without validation will be displayed in red. dFlow's flexibility allows other user groups to be identified by an extensive range of colors, thus providing more information to the access system.



dFlow accepts the main traditional identification technologies, including bar code, QR code, RFID, MIFARE, and biometrics via fingerprint. Integration into such technologies follow the standards used in the traditional access control equipment.



New biometric technologies now emerging, as facial identification, iris pattern identification, and finger on the fly are also supported by dFlow. These concepts offer a faster and contactless experience with the equipment, making the Free Flow concept even more pronounced.

7. Models

There are three types of models for dFlow. All of them use the same sensing system; however, each model has a different passage width.

I. Model 500

In this model 500, the passage width measures 520 millimeters. With such measure, we are able to have a bidirectional, non-simultaneous flow.

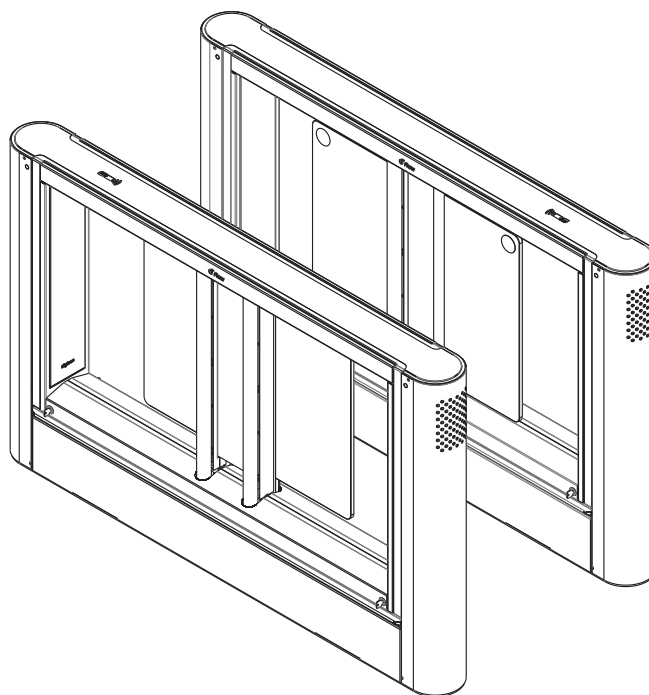

II. Model 900

In this model, the passage width measures 920 millimeters. With such measure, we are able to have a bidirectional, simultaneous flow as well as providing access to Special Needs Users.

NOTE- The model 900 can be configured with centralized doors.

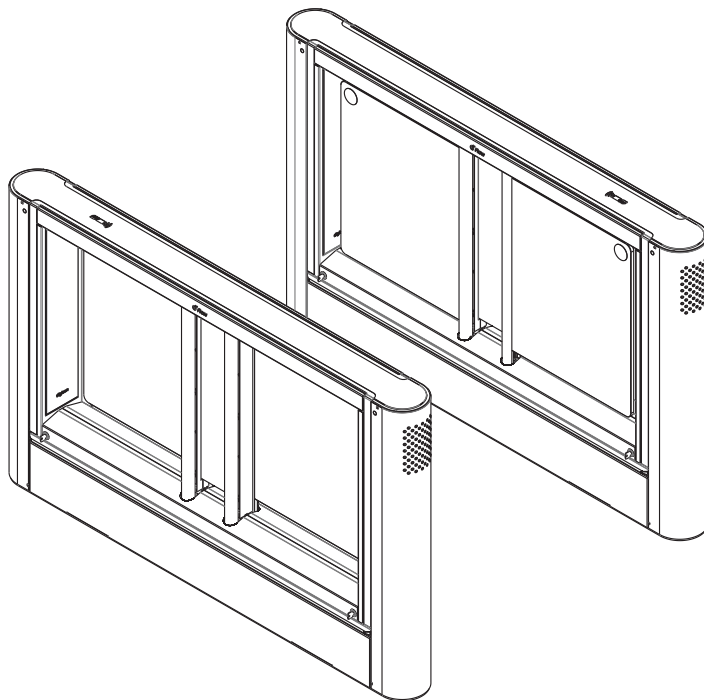

NOTE- Digicon meets the standard ABNT NBR 9050, Accessibility to buildings, furniture, and urban equipment.

III. Model 1100

In this model, the passage width measures 1120 millimeters. Exclusively in this model the doors are centralized, which does affect the bidirectional, simultaneous flow and allows access to Special Needs Users.

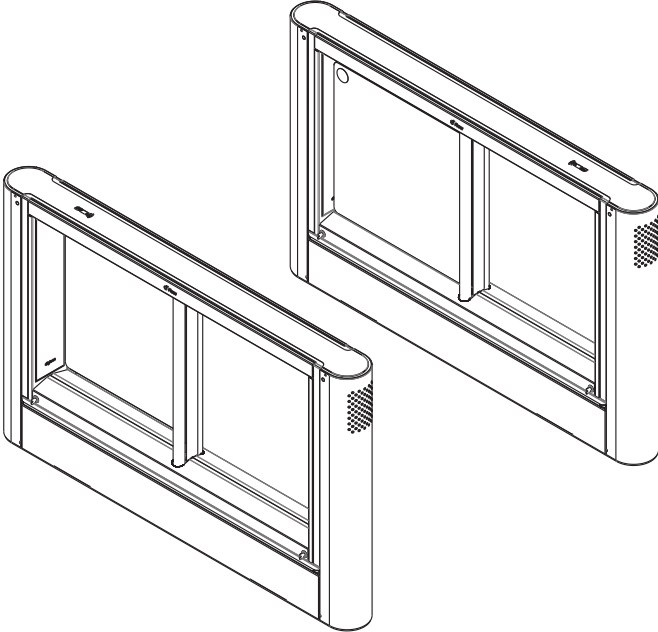

NOTE – Each dFlow passage has 2 bumpers (left and right) whose function is to protect the equipment against mechanical shocks. The bumpers, with 10 mm each, reduce the useful passage width from 1140/940/540 mm to 1120/920/520 mm in the active area.

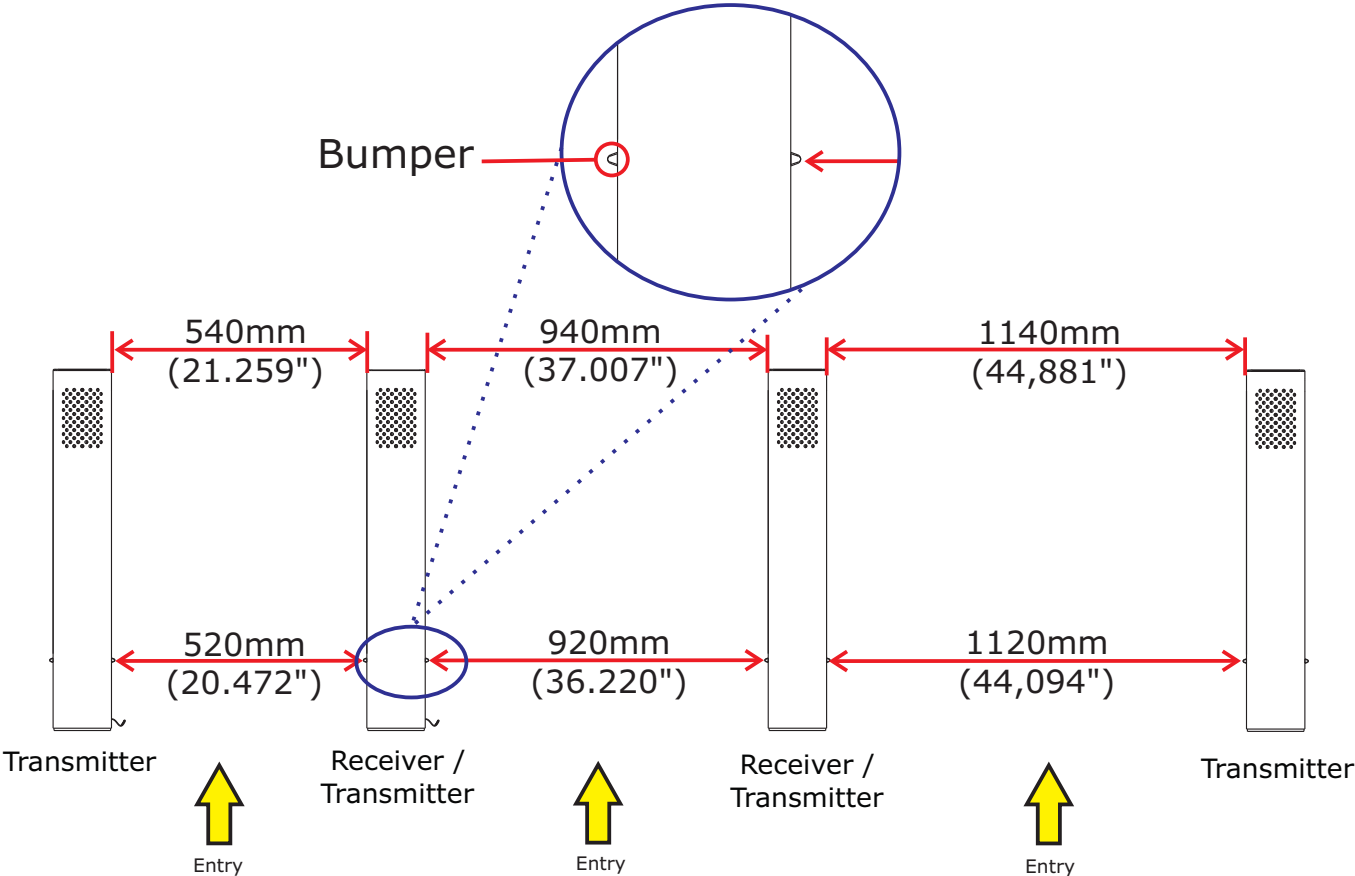

8. Installation

	<p>WARNING Allow only qualified personnel to install this equipment. The installation must comply with all local rules and regulations.</p>
--	--

8.1 Installation site

The installation site must follow the requirements listed in the document titled Work Plan in order to receive the equipment installation. In that document there are all the information needed to install the product correctly, so that it can meet the customer's expectations.

Alongside the document, there is a checklist of the installation requirements, which must be filled in, signed by the customers, and documented by the company responsible for installation.

NOTE –Evidences of the fulfillment of the installation requirements must be sent to the technician's analysis. That can be done via photos or videos, as long as they have clear information.

8.2 Package content

Before beginning installation, it is very important to perform a checklist of the received items. This helps prevent future stops during installation due to lack of materials. If you perceive any item missing, contact the company responsible for the sale.

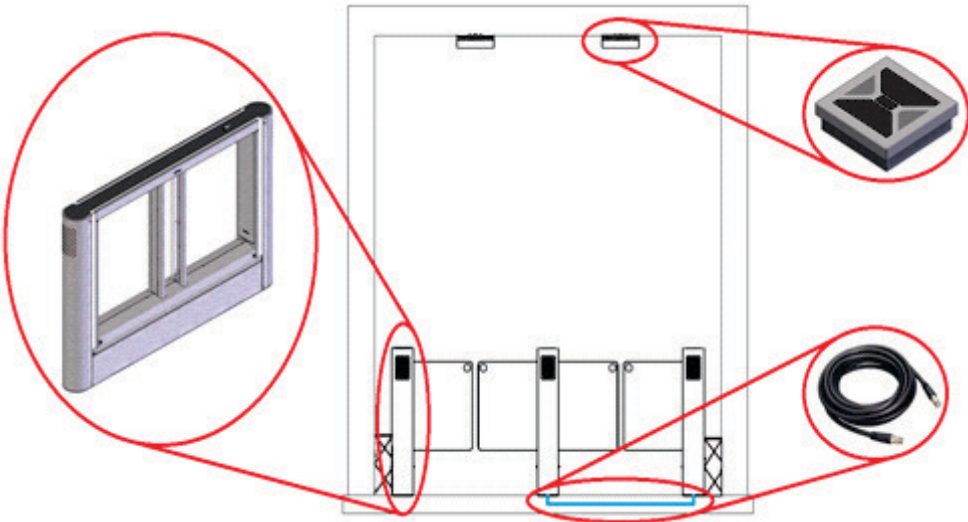

	<p>WARNING Use two or more people to move/install the equipment. Excess can damage or hurt someone who tries to perform this task alone.</p>
--	---

8.3 Accessing dFlow

Each equipment module has four covers accessible via keys:

- Side covers: offer access to the circuit breaker, collecting box, motor board supplies, and selector switch.
- Lower covers: offer access to motors, control board, CPU, terminals, and integrator area.

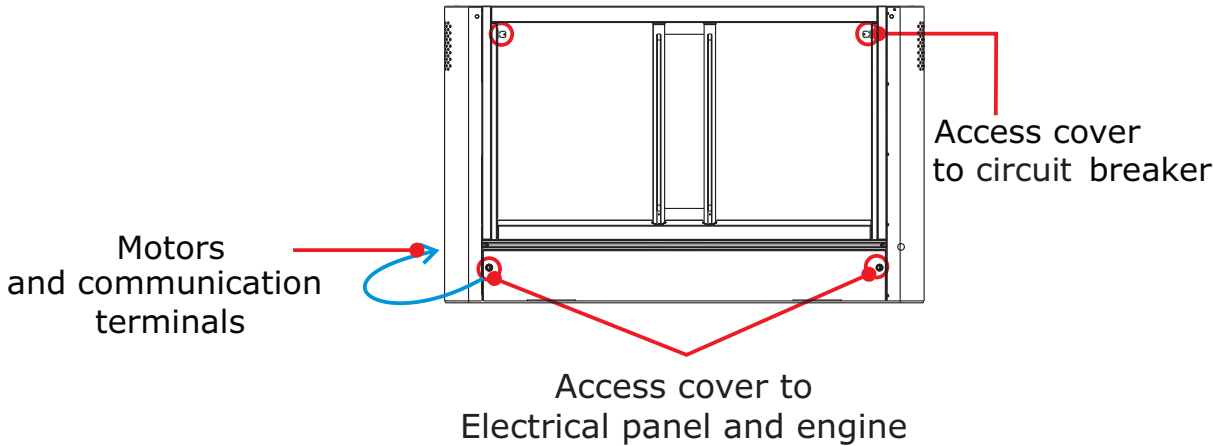

Opening doors:

Closing doors:

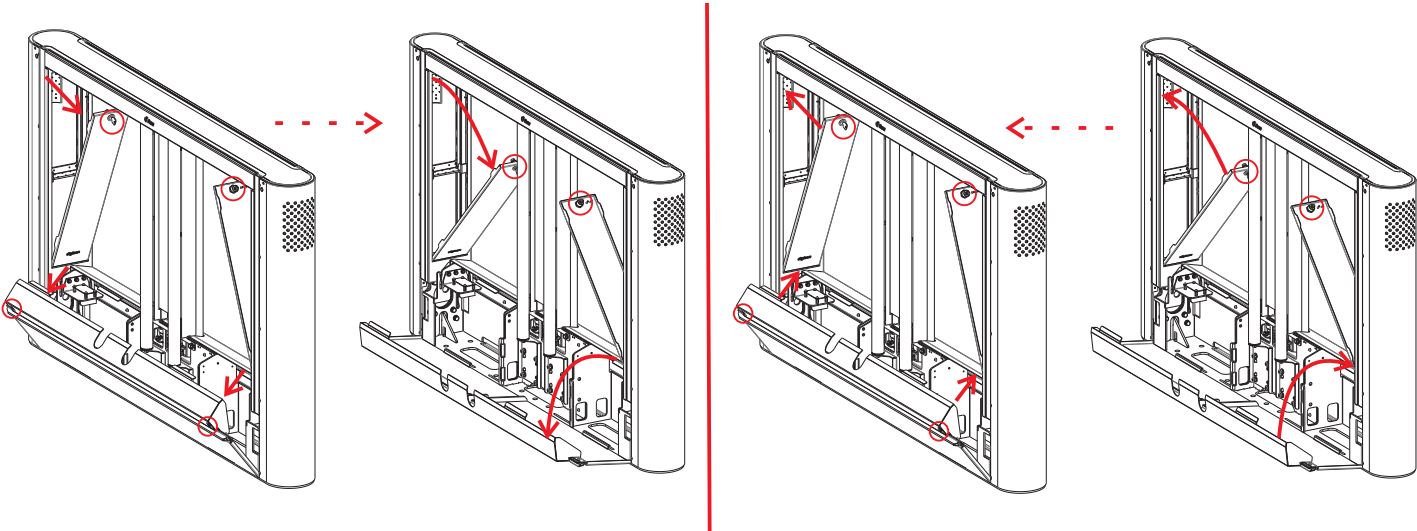

	<p>WARNING Make sure the circuit breaker is in the OFF position. This prevents the accidental equipment energization during installation.</p>
--	--

8.4 Drilling and anchorage

To anchor the equipment to the floor, we must prepare the drill holes according to the measures shown below:

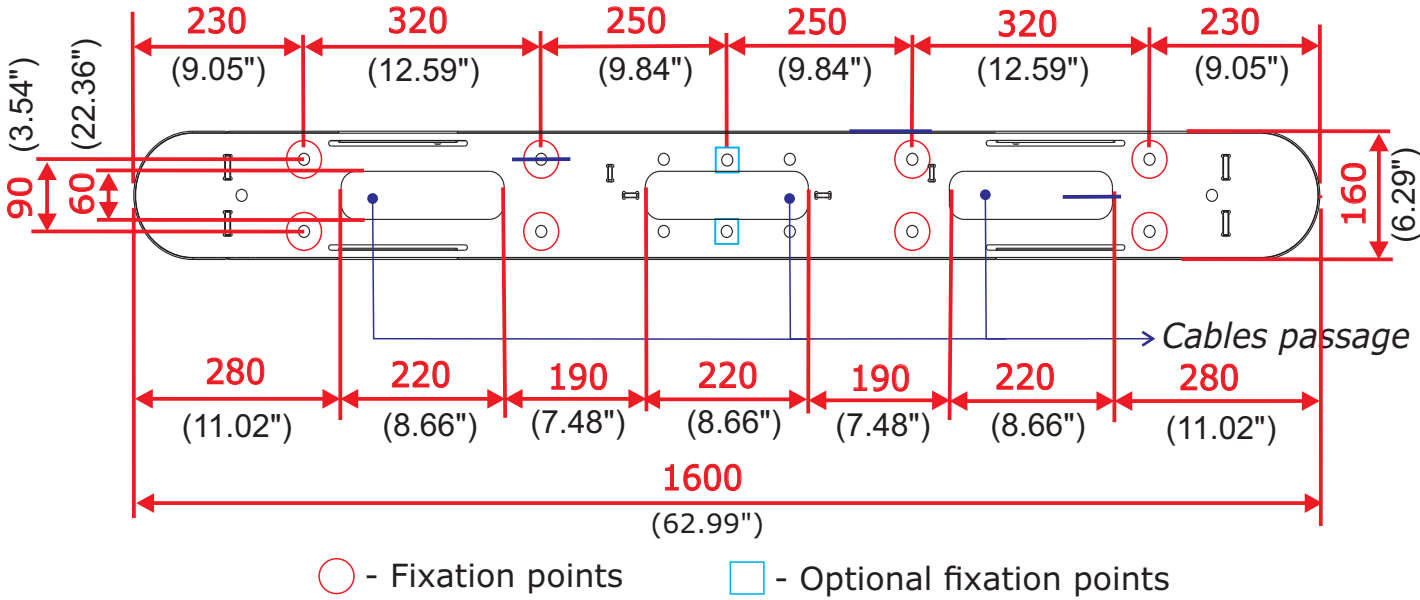

NOTE Make sure the installation surface is steady and leveled to ensure door alignment and a better sensor performance.

Place the equipment or templates in the correct installation place and check if it corresponds to the model purchased by the customer. Below you can see the measurements according to the models:

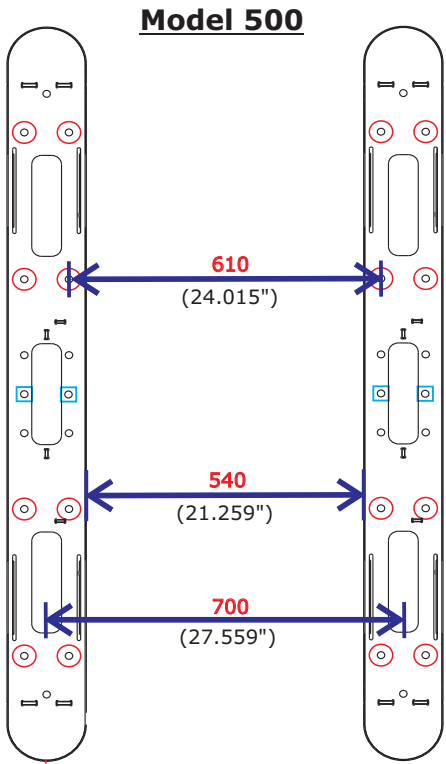

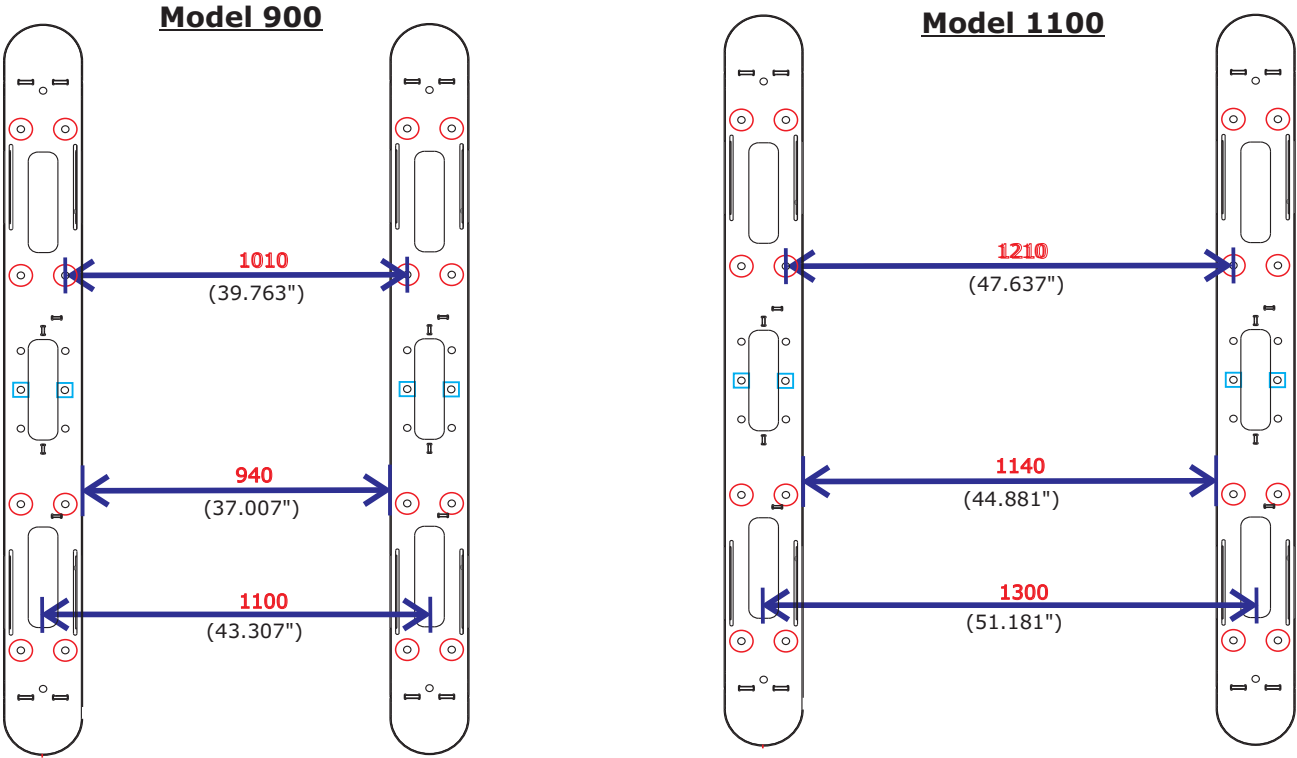

Once the layout is placed and the measurements are checked, mark the floor drilling points, remove the template and drill according to the chosen type of anchor (mechanical or chemical).

NOTE: Digicon recommends the chemical anchorage with ampoules. Check the manufacturer's information before performing the chose anchorage.

Make sure the modules follow the positions shown below:

Transmitter



Receiver

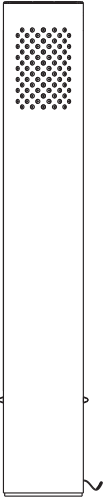

Entry

Transmitter

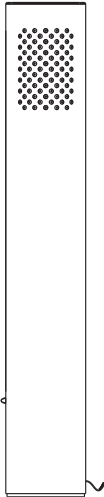

Transmitter/
Receiver

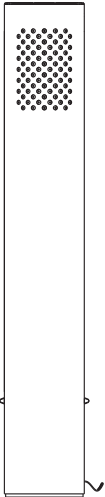

Receiver

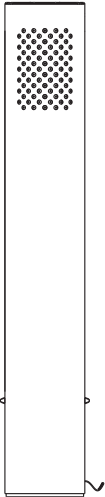

Entry



Entry

NOTE – In order to differentiate the modules, we point out that the receiver has the CPU and the control board while the transmitter only has the terminal block B2 in the lower half of the product.

8.5 Fixating and powering the sensor

To fixate the sensor correctly, check if the installation references are according to the ones specified below:

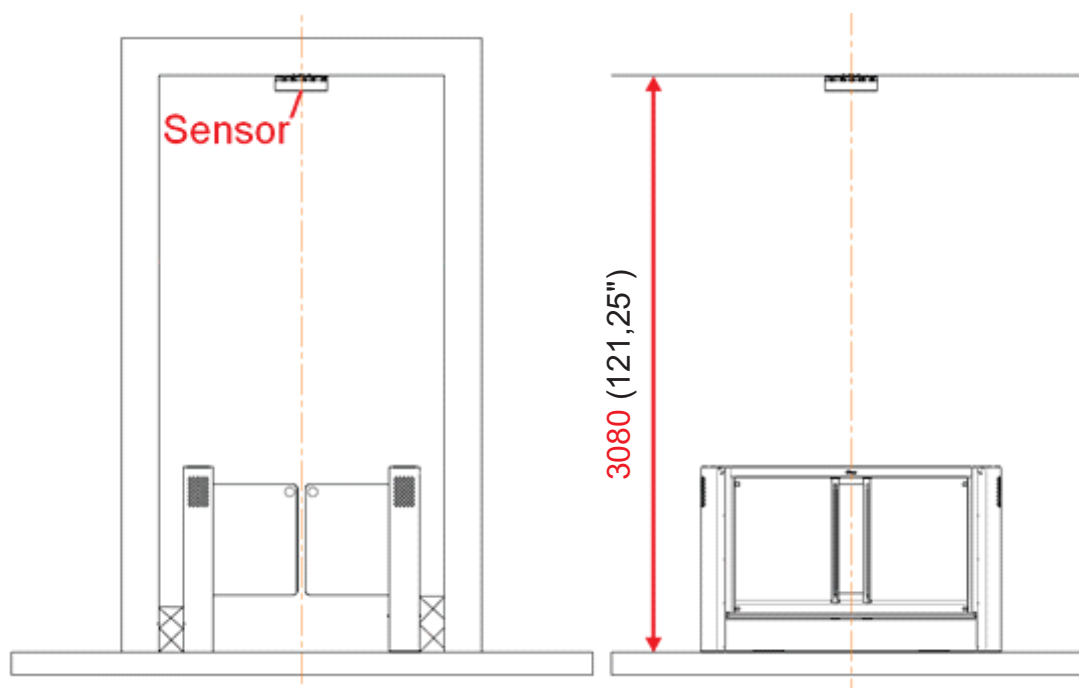

Inside the set, there is a kit containing screws and the connector used to power the sensor. Use these items to fixate the sensor to the structure organized by the customer.

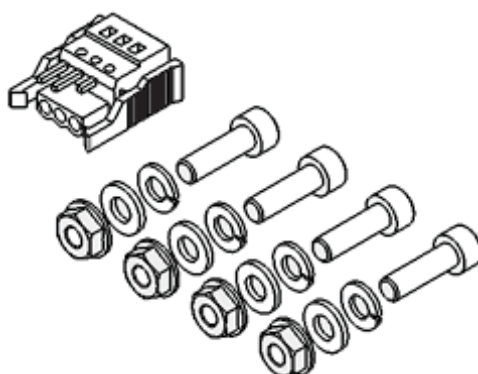

NOTE – If the anchor system provided does not fit the local requirements, it is possible to replace it as long as the new system does not mechanically interfere with the sensor.

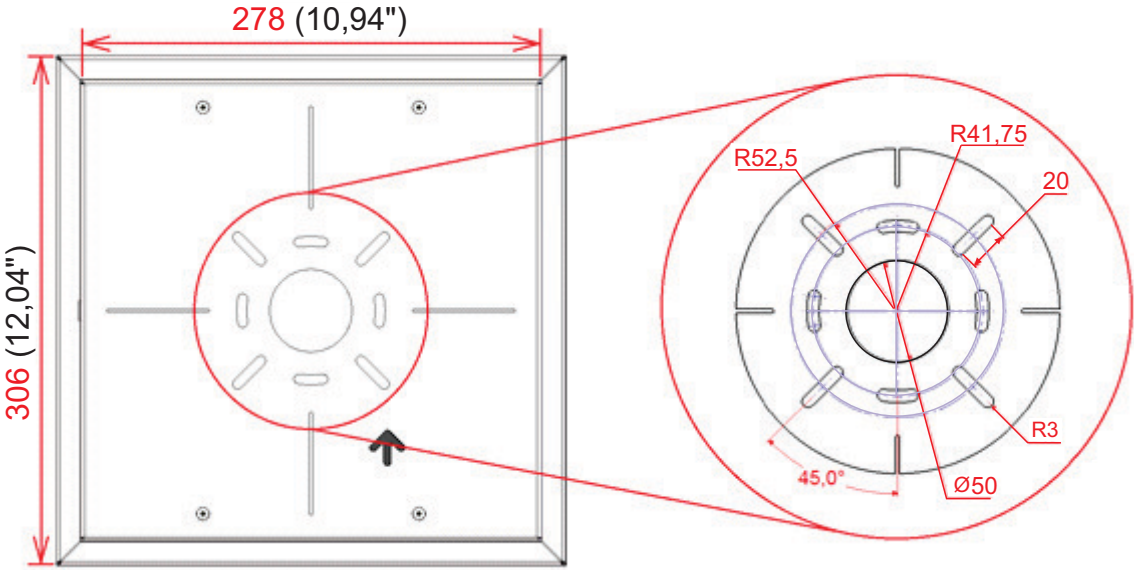

During installation, it is important to respect the correct position of the sensor. The engraving 'TR' on the fixation sheet guides the positioning of the transmitter and receiver modules while the arrow indicates the equipment's direction of entry.

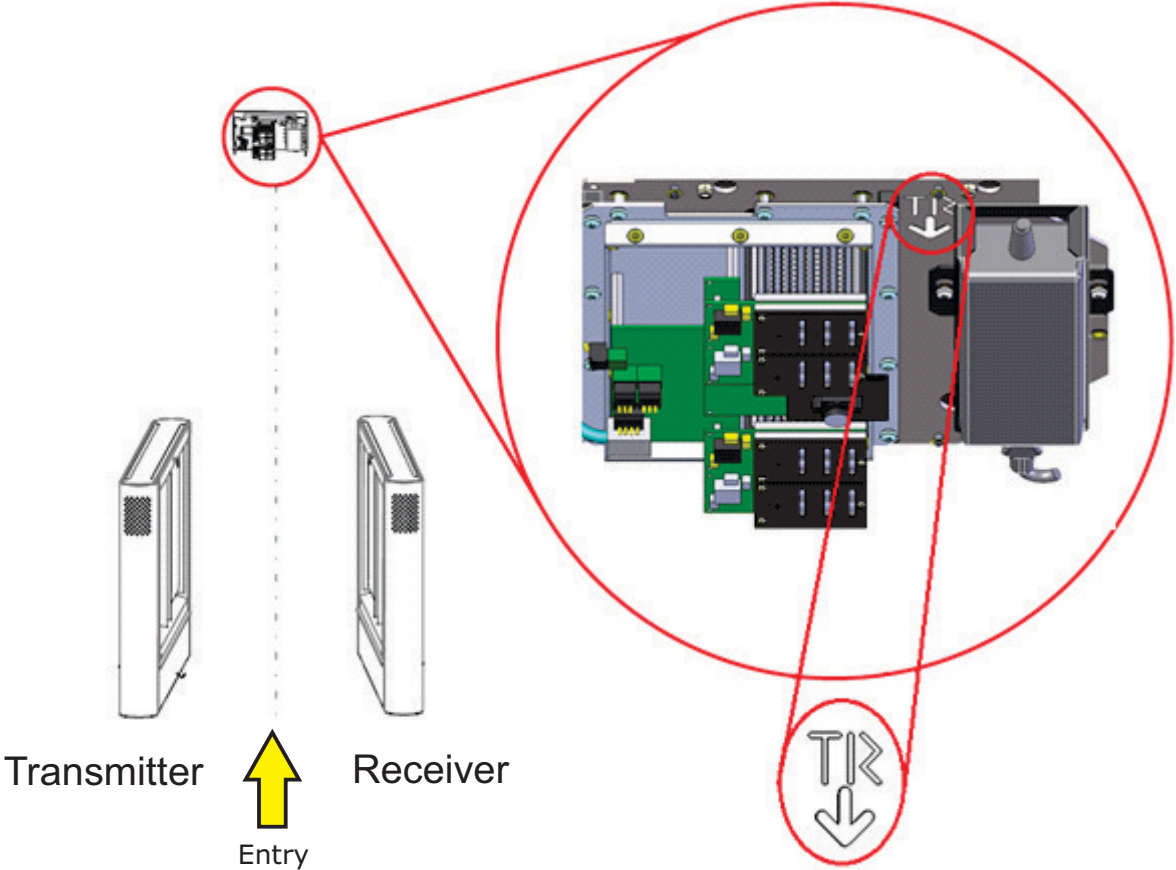

With the sensor adequately fixed, connect the cables that interconnect the sensor and the respective associated passage.

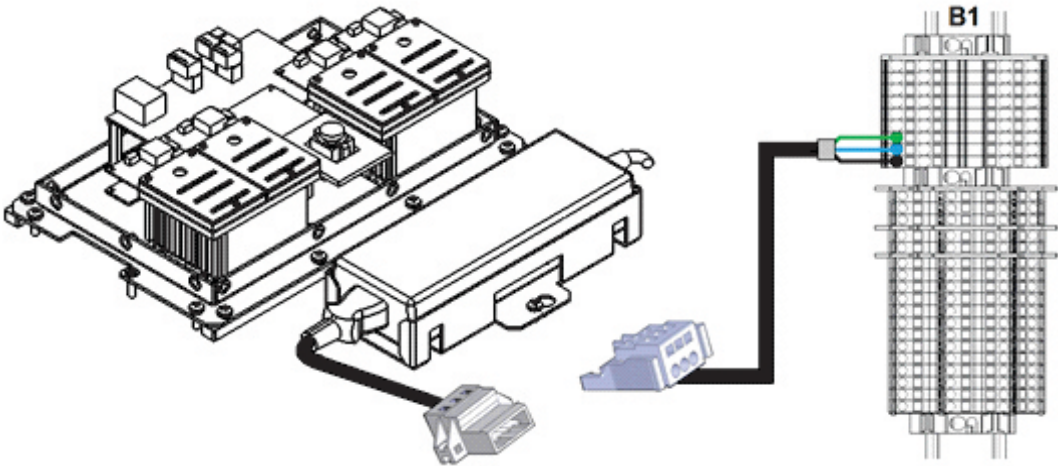
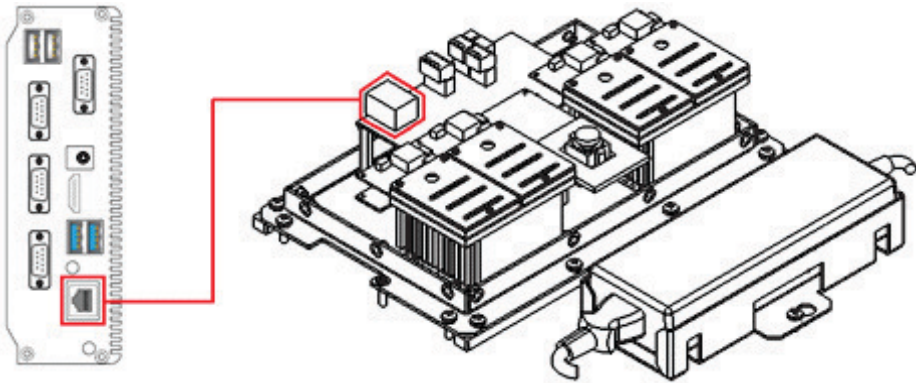
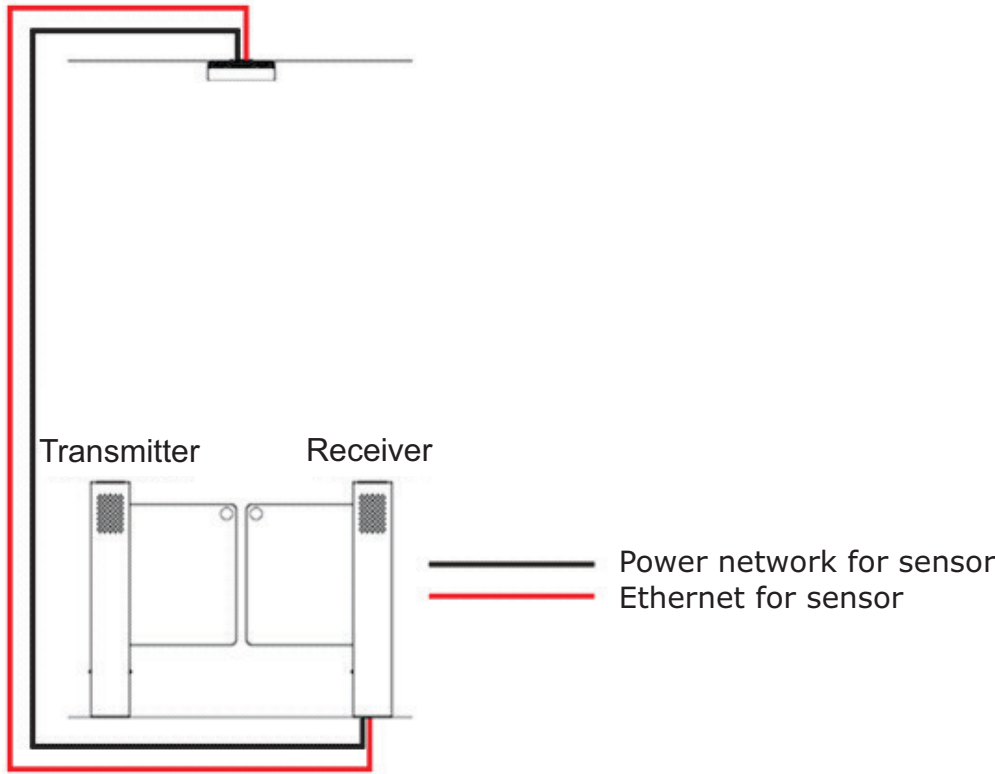

8.6 Routing of interconnection cables

After fixating the sensor and the modules, perform the module interconnection with the cables provided alongside the product. In total, there are five coded cables, as shown below:

- 037.12.376–AC supply
- 037.12.377–5VDC supply
- 037.12.378–Peripherals communication
- 037.12.379–Pictogram communication
- 037.12.380–Signals communication

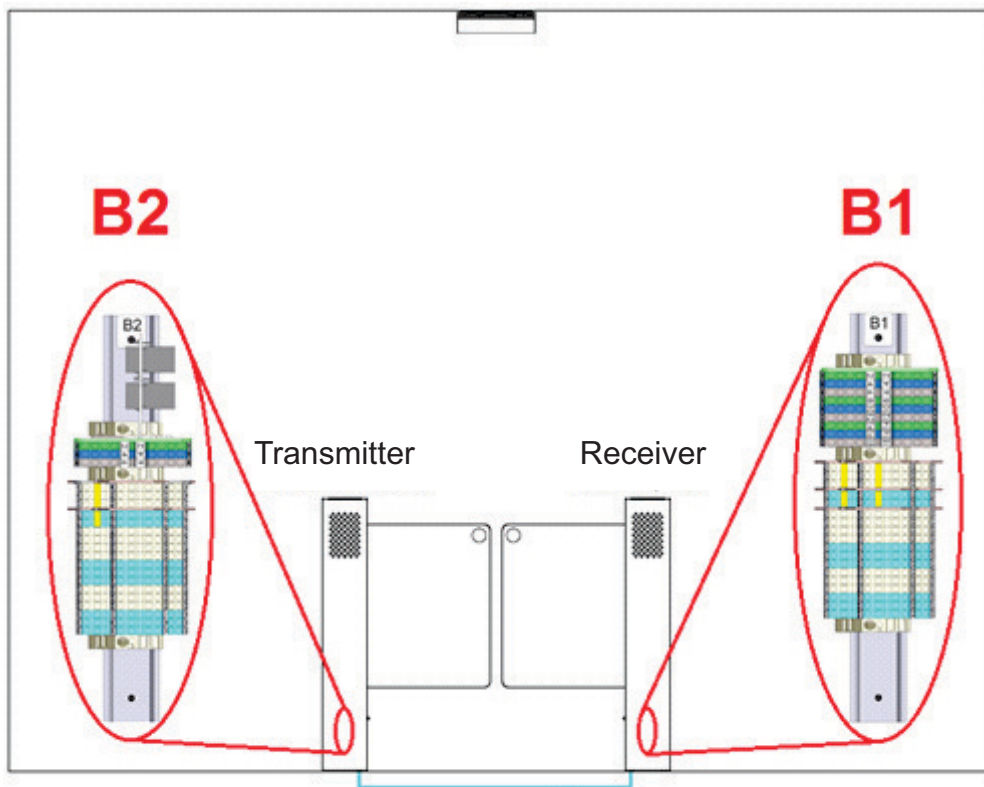

The interconnection must be done between the receiver and the transmitter modules, that is, between terminal blocks B1 and B2. Each cable has the terminal block prefix in its identification.

NOTE – Digicon provides 4-meter interconnection cables. The depth of the ducts must be measured so that the cables are enough.

NOTE – Pay attention to the route identifiers on each cable. Inverted connections can harm equipment performance.

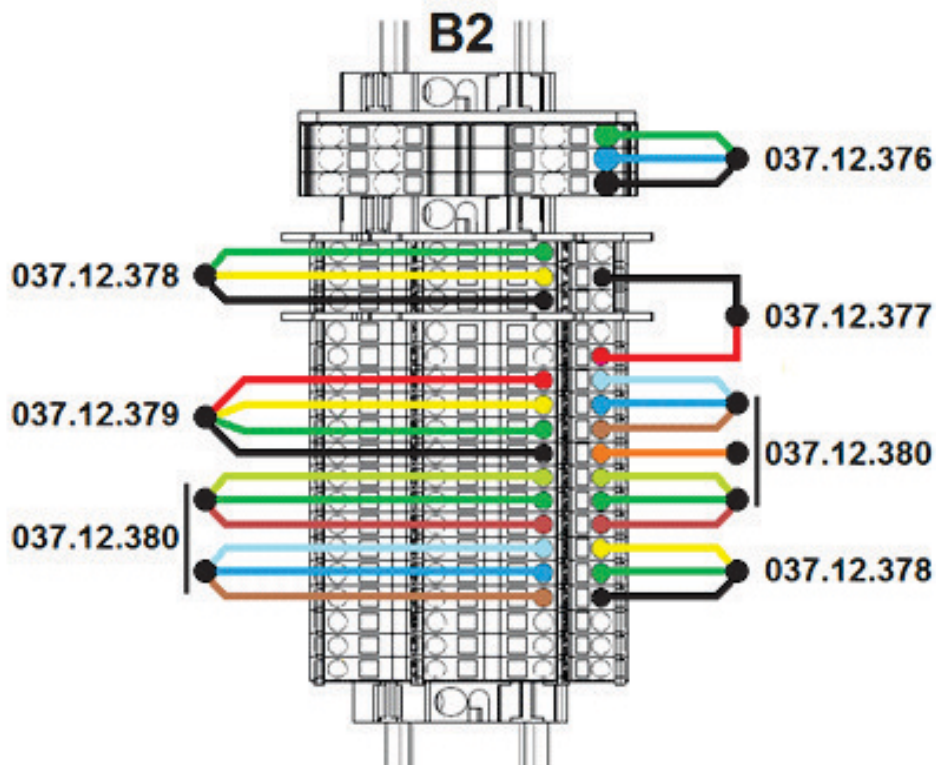
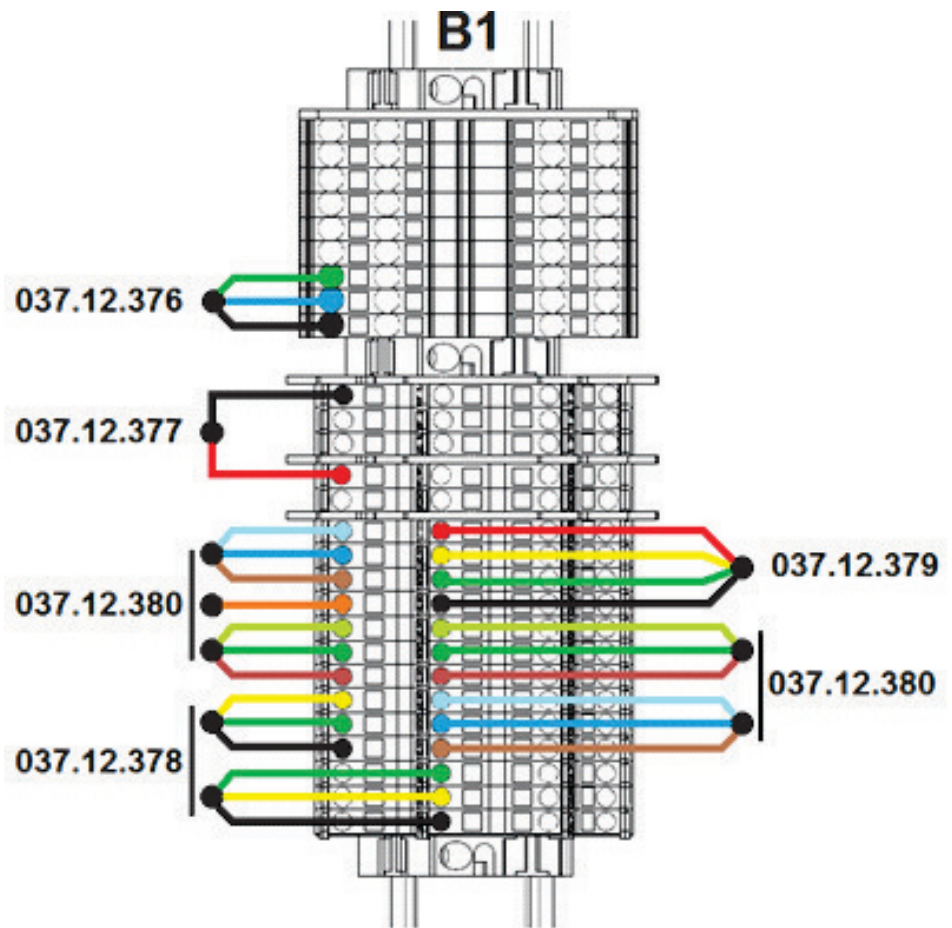

NOTE- when passing the interconnection cables through the infrastructure, be careful not to damage them. Broken cables harm equipment performance.

8.7 Power connection and external network

To power the equipment, the external alternate current must be connected to the specific terminals 1, 3, and 5 at terminal block B1. The rest of the terminals of the upper part are currents protected by the equipment circuit breakers.

NOTE - Check if the cables provided for the connections meet the manual specifications (Work Plan).

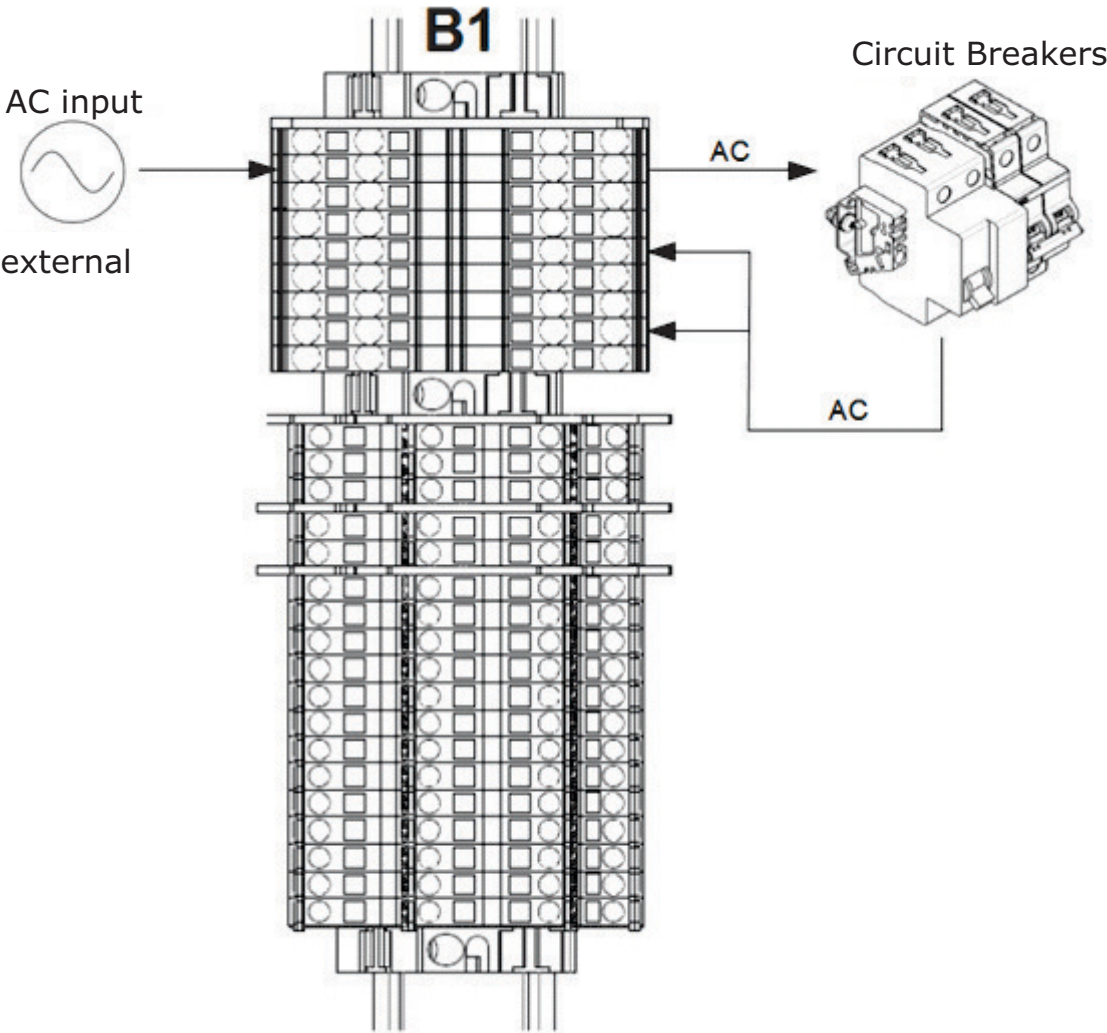

WARNING
The green-colored terminal is exclusively reserved for grounding; thus, do not input alternate signals into these connections.

For the logical part, the network cable must be connected in the slot located in the tray beside terminal block B1, as shown in the image below:

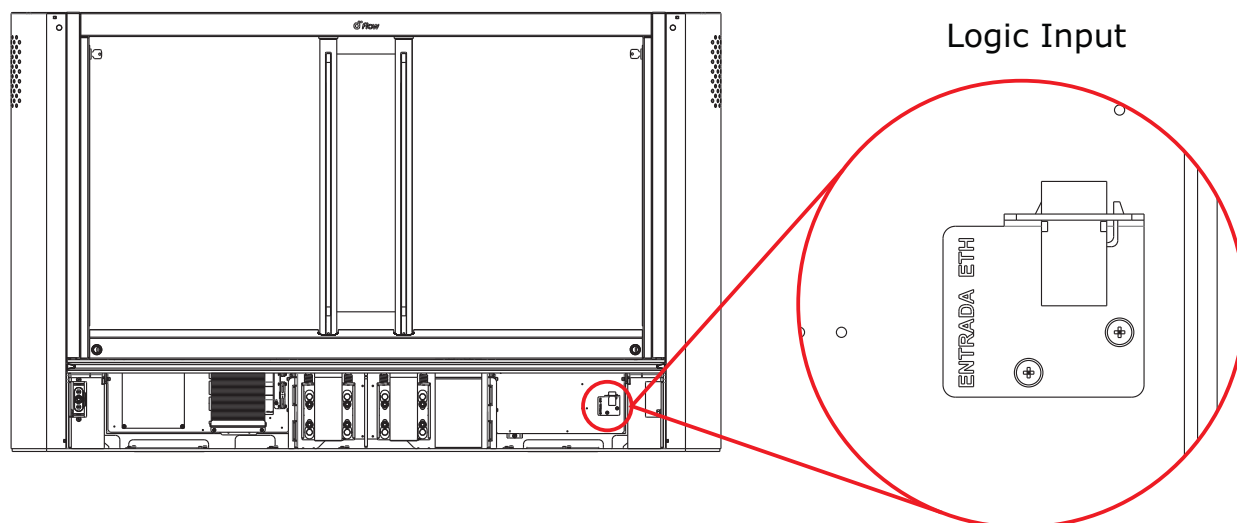

9. Powering the equipment

9.1 Important checks

a) Check if the doors are free to move along their path.

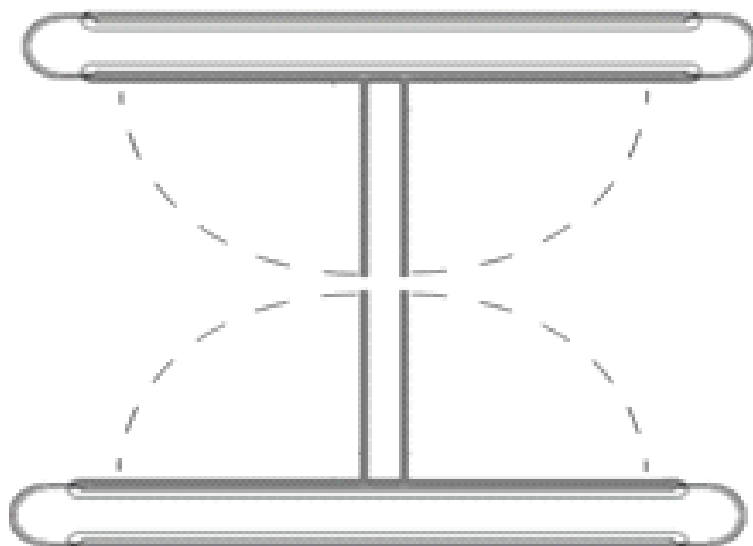

a) With a multimeter in the continuity scale, check if the equipment's inner alternate supply is not in short circuit.

b) Check also the continuity between the interconnection cables between terminal blocks B1 and B2.

d) Make sure the mandatory free space is respected.

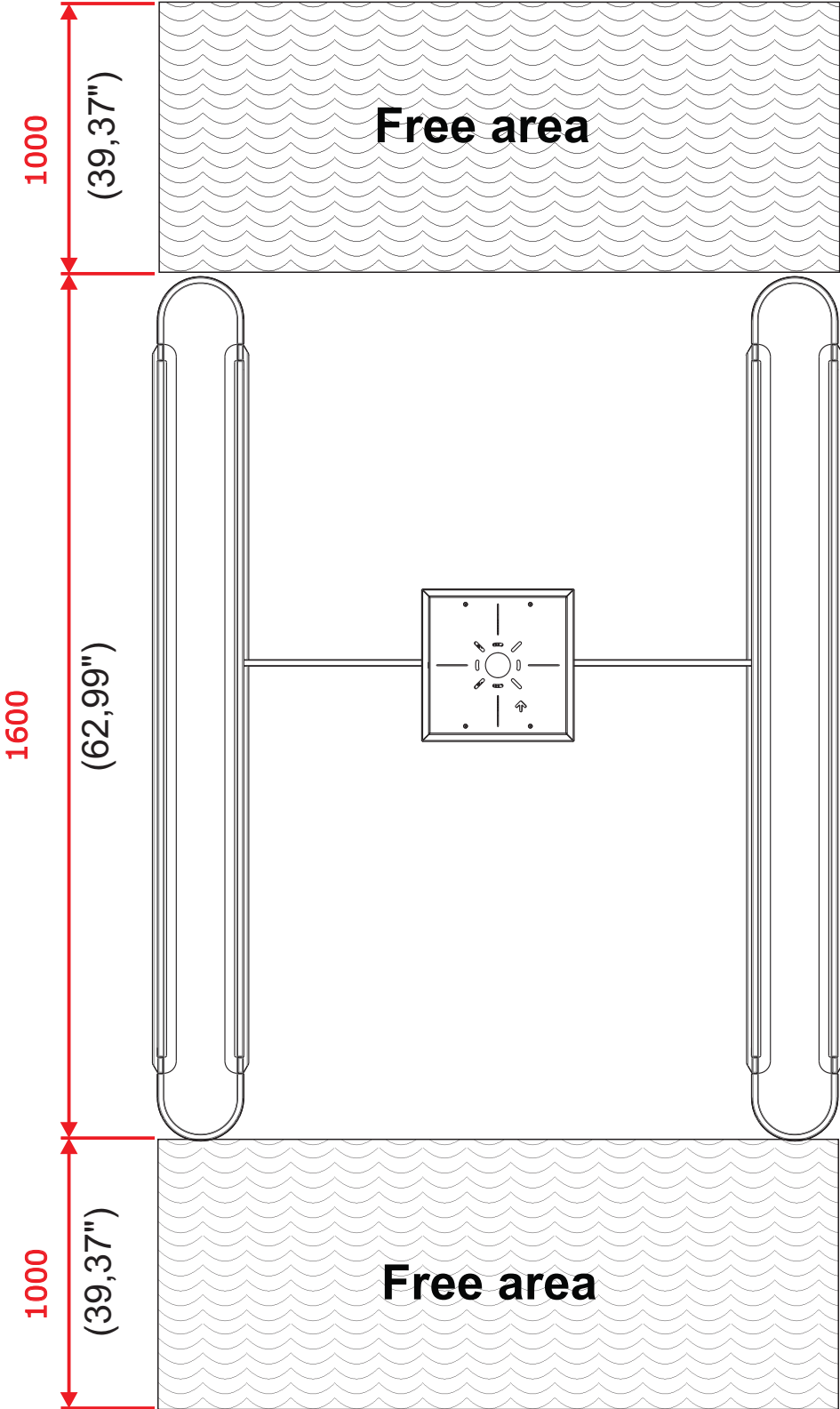

9.2 Turning on the circuit breaker

After performing the check, the equipment can be powered for the first time. Access the side cover that gives access to the circuit breakers and turn them on.

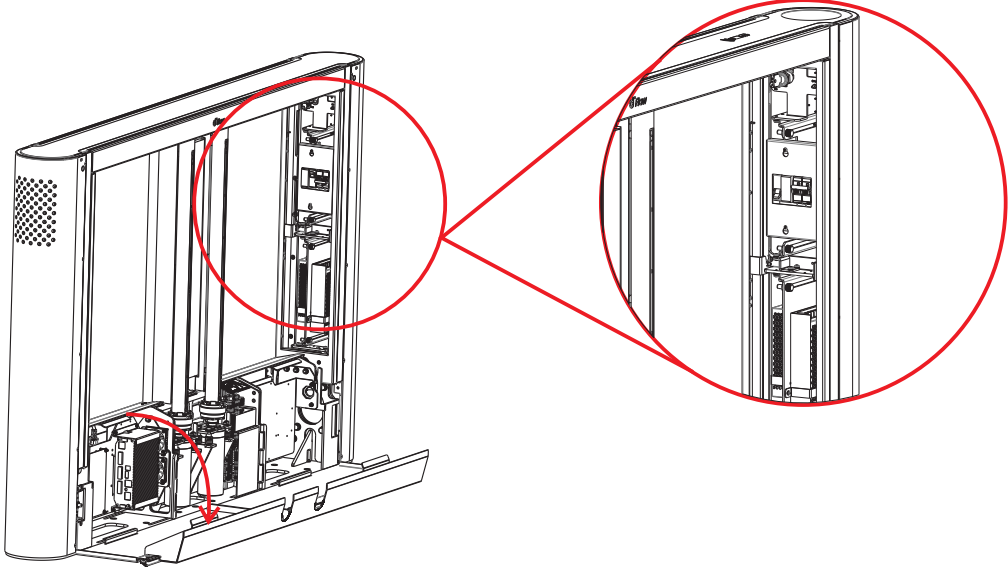

After powering the equipment, wait for a few minutes until the application starts to run in the equipment. As soon as the doors open and the frontal pictogram indicates open passage (<), the equipment is ready for the first setups.

10. Configuration via selector switch

Many of the dFlow adjustments and configurations are available in a practical and fast manner. Through the selector switch, many functions can be performed: validation and calibrations of upper sensor, door centralization, change of entry and exit operational states, and alteration of upper LED color. To activate these functions, turn the switch and press the OK button.

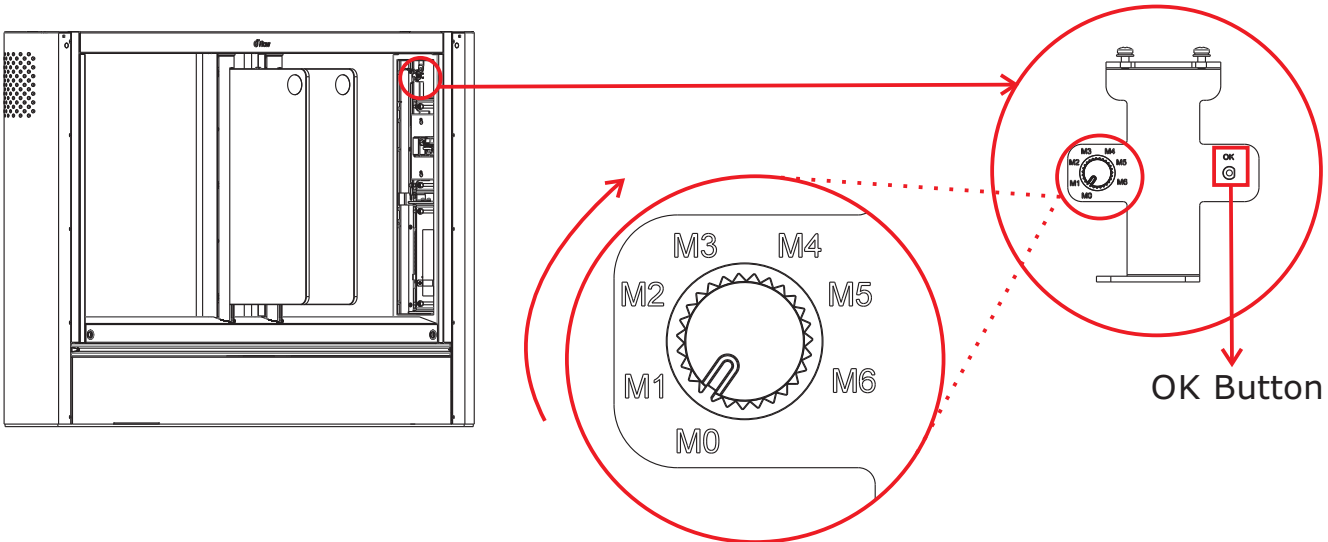

Position M0 – Normal operation

Briefly press the OK button to return the equipment to its normal state.

Position M1 – Validate sensor calibration

This function is important to check the quality of the calibration being used. When you briefly press the OK button, all the LEDs light up in the color red. Step away from the blockage and make sure there is nothing in the blockage's area, according to the specifications.

NOTE - This function has limited executing time. After 1 minute, the equipment will return to its normal state. If you do not want to wait through the limit time, it is possible to exit the function by going back to the M0 position by briefly pressing the OK button.

If the color orange is identified on the LEDs, it means the calibration is incorrect.

An ideal calibration is identified by the static color red, that is, the color orange is not activated in the process of calibration validation.

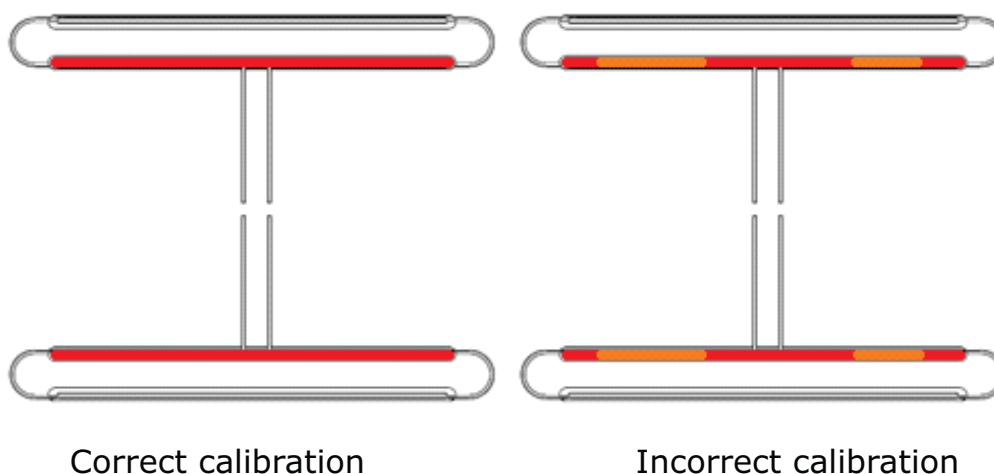

In case of incorrect calibration, execute the sensor calibration procedure.

Position M1 – Sensor Calibration

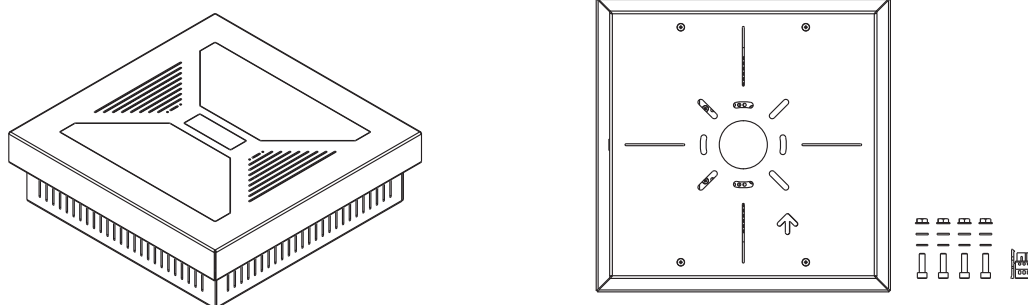

Sensor calibration is an important resource for the equipment's optimum operation. This procedure is applied when there are alterations in the installation environment and/or when incorrect calibration is identified.

By pressing the OK button for 3 seconds, the equipment will start the calibration process. Remember to step away from the equipment so to not affect the process. The phase's progress can be seen on the red-colored LEDs. After calibration, the equipment will return to its normal operation.

Position M2 – Door calibration

The door calibration procedure is applied when we identify that the doors are not orthogonal to the blockage, that is, they do not form a 90° angle with the module.

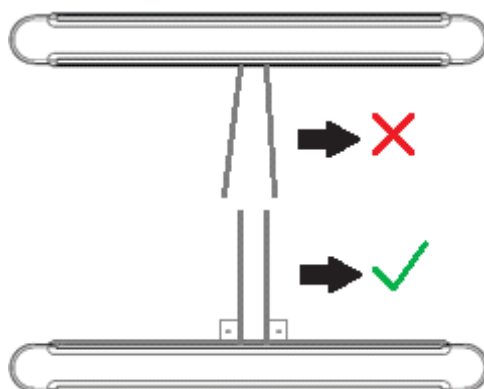

This procedure is divided into two phases: verification of opening edges and door centralization. By briefly pressing the OK button, the equipment will start the process of verifying the edges. After the first phase is finished, manually adjust the doors orthogonally to the module position and press the OK button again. The progress of both phases can be seen in the purple-colored LEDs operation.

After the procedure, the equipment will return to its normal.

Positions M3 and M4 – Entrance and Exit Operational States

The operational states can be set up in three ways, which are:

Controlled = Only accepts passages who present valid credential. It is represented by the color chosen in the procedure of position M5 and with a '<' on the corresponding pictogram.

Free = State that does not require credential to grant access. It is represented by the color green.

Closed = State that invalidates passage in the direction signaled. It is represented by the color red in the side LEDs and with an 'X' on the corresponding pictogram. By pressing the OK button in the position M3, the entrance operational state is altered.

If we perform the same procedure in the position M4, the exit operational state is altered.

Press the OK button until you reach the preferred state.

NOTE - If the equipment is set up in the unidirectional mode, the state alteration in the exit direction will have no effect.

Position M5 – Operational colors

It is possible to choose the color to be displayed in the controlled mode. The color options are yellow, blue, orange, turquoise, white, purple, pink, olive, and brown. Press the OK button until you reach the color of your choice.

Position M6 – Protection levels

The equipment's security levels aim at avoiding collisions between door sheets and users. This control occurs through delimited areas, which act in controlling the door activation according to the rules of the level selected. The upper LEDs identify the selection according to the level.

- Red (Level 0): No protection
- Orange (Level 1): Only valid users
- Yellow (Level 2): Any user
- Green (Level 3): Any object



Press the OK button until you reach the preferred security level.

11. Optional items

Besides providing compatibility with most access control technologies, Digicon also offers a series of optional items that allow improve and adjust the dFlow operation to the customer's needs. You can read the description of each item below:

11.1 Card collector

The collector kit with box has a device for collecting, retaining, and retrieve cards and badges. It is ideal for place with eventual visitors or users. The kit is composed of a slot, a solenoid-driven retrieval device, and a storage box. The box can storage approximately 50 cards.

The image below shows the items that compose the collector kit.

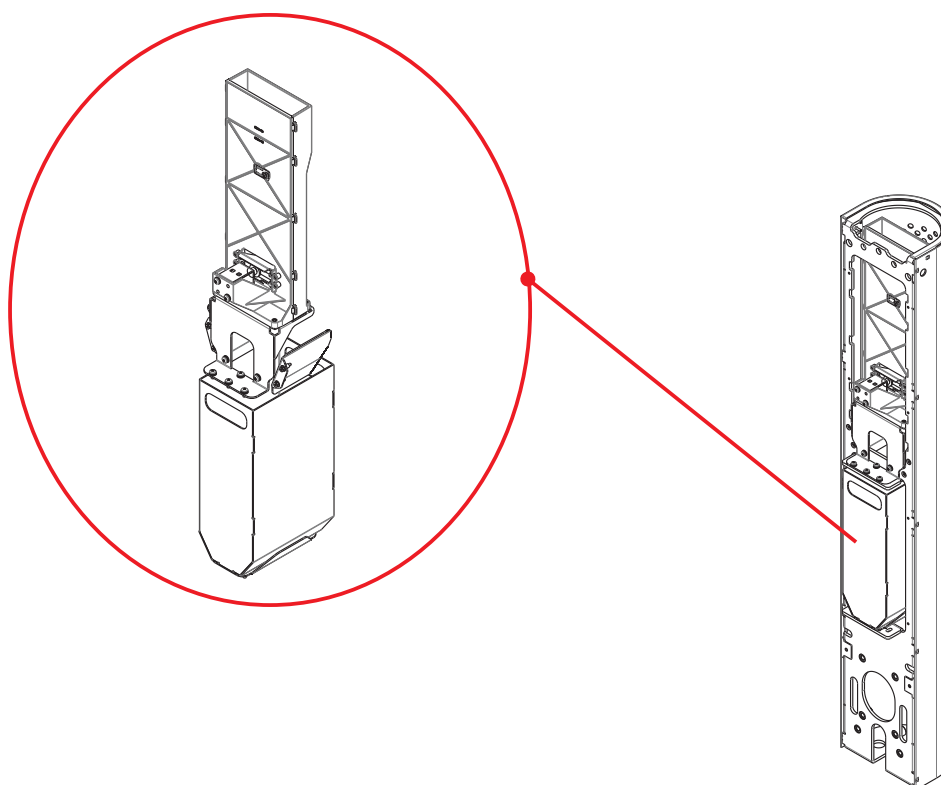

11.2 Display



The LCD display has Full HD resolution and presents informative images of the equipment's action and operation. These images are configurable, that is, they can be personalized according to the customer's needs.

See some of the existing patterns below:



11.3 No break

The no break has the function of opening the door in case of power outage. This occurs through the integrated battery that provides the necessary current to power the activation engines, thus ensuring that the passage is not interrupted during the outage period. When the power is back, the equipment restarts and goes back to normal operation.

11.4 Bar code reader

It has a sensor with resolution of 844 x 640 pixels operating at 60 FPS, which reads bar codes and QR codes. This optional item is largely used for scanning boarding passes at airports.

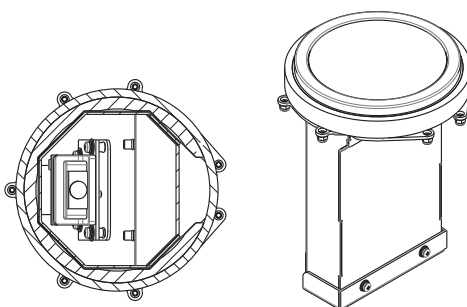

11.5 Access control module - MCA

This module is a technology developed by Digicon with the goal of maximizing the task of integrating access control systems that demand processing power, flexibility when choosing technologies, and agility in manipulating and transferring data. The following items are optional and can be configured alongside the MCA:

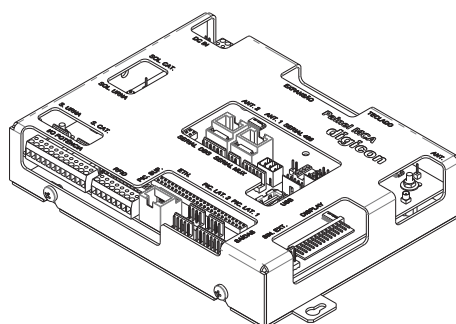

11.5.1 Antennas

Antennas are used for reading cards and have a wide application in commercial and business environments where a controlled flow of people is desirable. The MCA already has integration with the MIFARE and RFID technologies and is available to integrate other antennas according to the customer's needs.

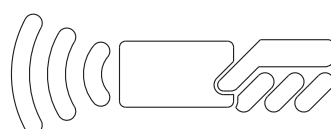

11.5.2 Biometrics

The biometric sensor is a device designed for identifying people through fingerprint scanning. Systems that use this type of identification are safer and more comfortable since they do not need to offer another type of identification to validate.

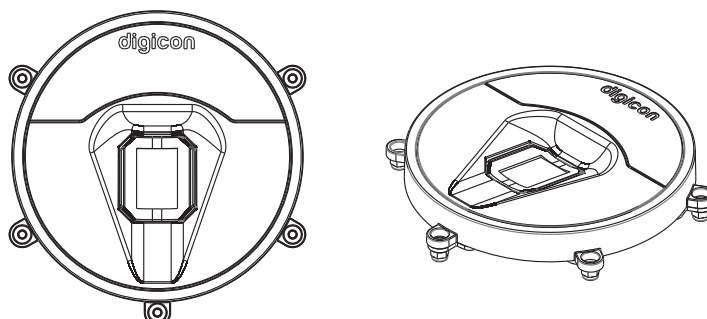

11.5.3 Bar code reader

It has a sensor with resolution of 752 x 480 pixels that reads bar codes and QR codes. This optional item is largely used for scanning boarding tickets at airports.

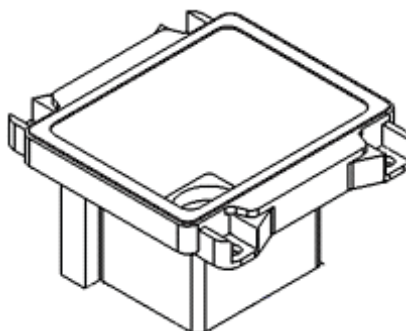

12. Technical characteristics

12.1 Dimensions

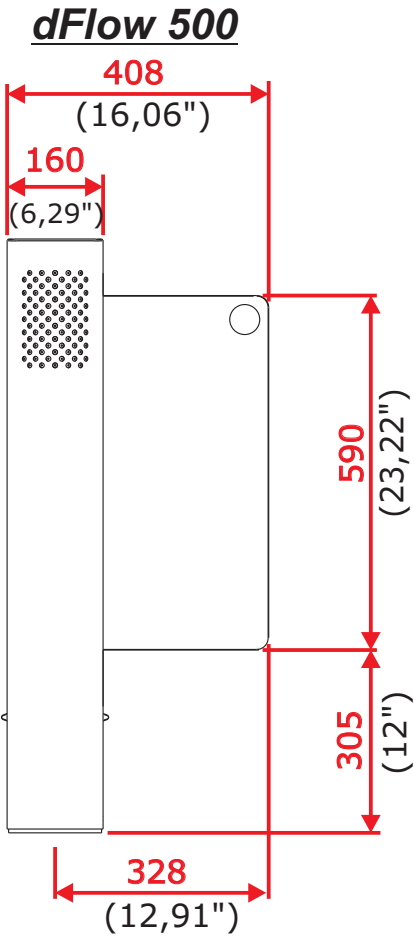
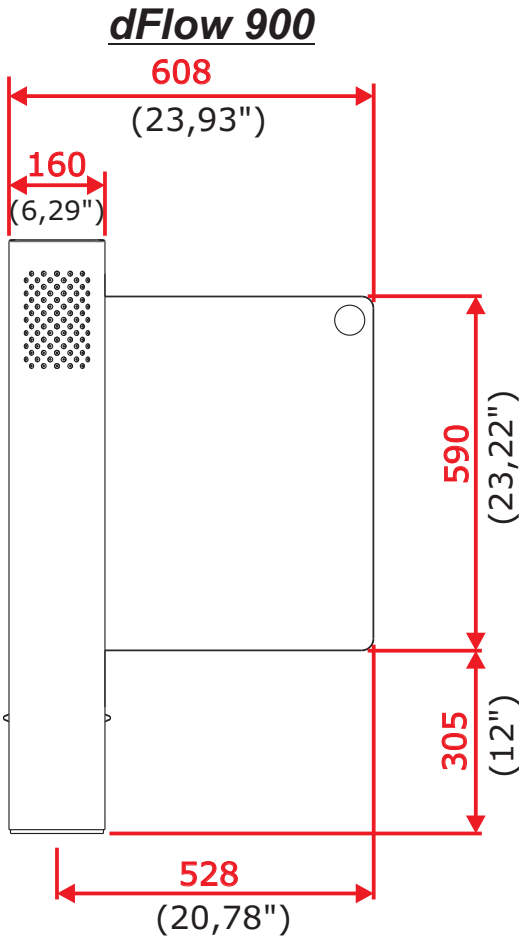
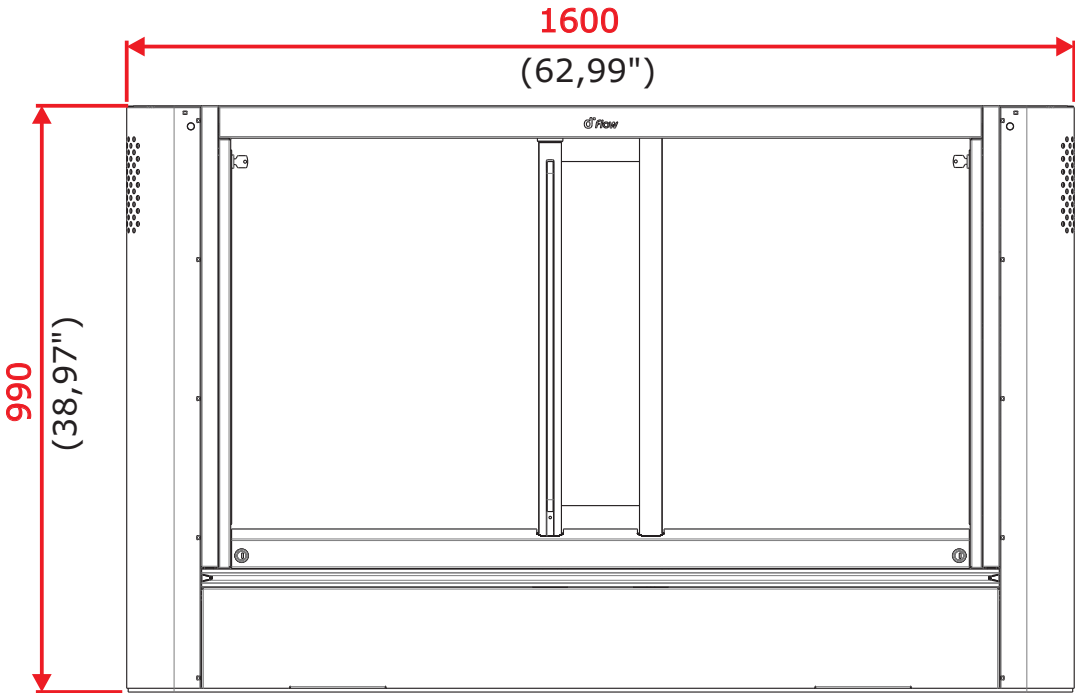

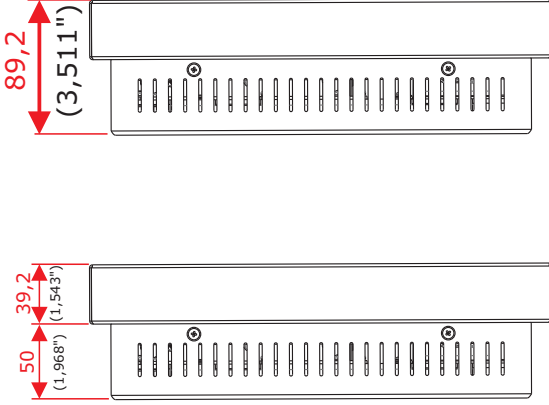
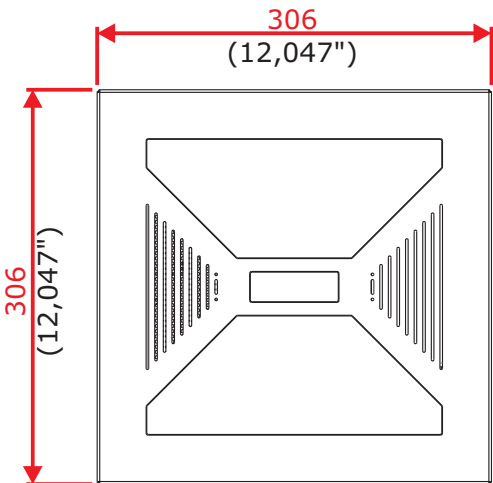
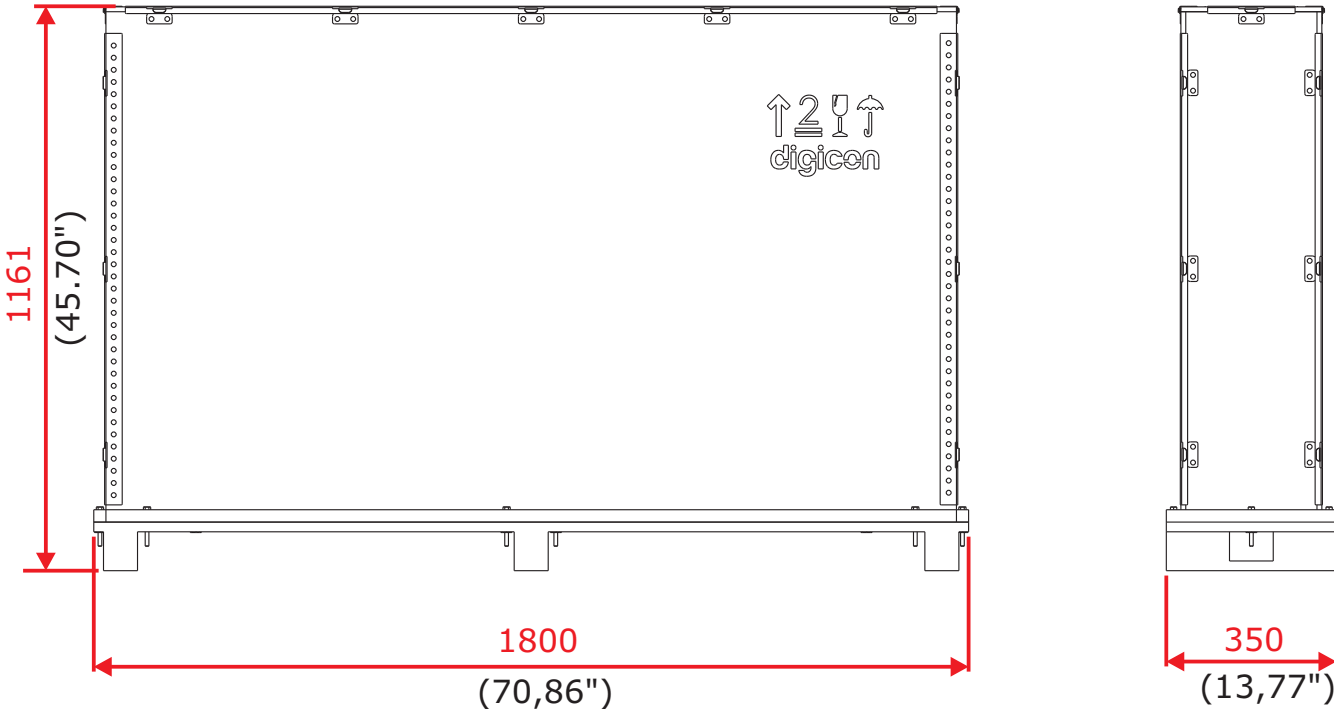

NOTE-dFlow measures are provided in millimeters and (inches).

12.2 Other information

Technical Data	Characteristics
Power Supply	100 - 240 VAC (automatic selection)
Frequency	50 - 60 Hz
Average time for opening/closing door	1 second
Operating temperature	0°C to 50°C
Approx. weight	190kg per module

Consumption:

Booting	140 ~ 150 W
Operation (standby)	120 ~ 140 W
Operation (two doors in movement)	120 ~ 160 W
Operation (two doors blocked)	160 ~ 200 W
Operation (four doors blocked)	160 ~ 280 W

13. Preventive maintenance

Leave all maintenance services for qualified technical professionals.

Action	Frequency
Check operation of 3D sensor, analyzing video files generated	1x / 6 months
Calibrate blockage	1x / 3 months
Calibrate doors	1x / 3 months
Analyze door operation, looking for noises, heavy mechanisms, and non-standard activations	1x / 6 months
Analyze side and upper LED lights activation	1x / 6 months
Analyze activation of entry and exit pictogram	1x / 6 months
Analyze activation of buzzer through validations and invalid entries	1x / 6 months
Check operation of coolers that ventilate CPU	1x / 6 months
Check 5V and 12V voltages at terminal block	1x / 6 months
Check 24V voltage in motor supplies	1x / 6 months
Check activation of equipment emergency	1x / 6 months
Check operation of doors' mechanical brakes (*)	1x / 6 months
Check operation of biometric reader(s) (*)	1x / 6 months
Check operation of contactless card reader(s) (*)	1x / 6 months
Check operation of card collector and box (*)	1x / 6 months
Check operation of bar code reader(s) (*)	1x / 6 months
Check operation of display (*)	1x / 6 months

(*) = If installed

- On the next page, there is the model for the document where all maintenances must be recorded.

14. Cleaning

14.1 Maintenance and conservation of doors

- Finger marks: use a soft cloth moisten with water, soap, or neutral detergent and slightly polish the surface a dry and soft cloth.
- Stains can appear after dirty water dries. Use a soft cloth moisten with distilled or ionized water and dry the area well with a soft and dry cloth.
- Grease and oils: use a soft cloth moisten with isopropyl alcohol. Be careful to not spread the stain.
- Check the fixation of the doors' support every six months.

14.2 Maintenance and conservation passage control sensor

- Clean the lenses every month, at least. Take into consideration the environmental conditions and application to adjust the cleaning period as you see fit.
- If the cleaning is regular, only water is enough.
- Do not use chemical products, bleaches, or house cleaning products.
- If the dirt accumulated is thick, apply neutral soap and use a soft cloth or a softbristled brush.
- Use neutral soap – when and if necessary.
- For heavier cleanings, use isopropyl alcohol with a soft cloth.
- The lenses are sensible to abrasion – remember that when cleaning them.
- Make sure to clean the body covers properly – soap or alcohol residues can stain the lenses.

14.3 Maintenance and conservation of dFlow (glasses and stainless steel sheets)

- Clean the equipment at least once a month. Take into consideration the environmental conditions and application to adjust the cleaning period as you see fit.
- If cleaning is performed regularly, only a dry cloth is enough to remove the dust.
- Do not use chemical products, bleaches, or house cleaning products.
- If the dirt accumulated is thick and there are stains from handling of users, use isopropyl alcohol with a soft cloth.
- Brushed stainless steel and glasses are sensible to abrasion; remember that when cleaning them.
- Make sure to clean the body covers properly – soap or alcohol residues can stain the lenses.

15. Warranty and Technical Assistance

Digicon is responsible for the project, skilled labor, and quality of the materials used in the manufacturing of our products, ensuring that the equipment and all parts are free of manufacturing defects or problems. Digicon commits itself to replace or repair, as we choose, any part or equipment presenting manufacturing defects without any costs to the buyer, in our factory in Gravataí or our branch office in São Paulo, in the conditions set below:

1.The buyer is responsible for the costs of shipping (return service) of the product to the factory in Gravataí (Rio Grande do Sul) or the branch office in Barueri - São Paulo.

2.The warranty period is counted from the date of emission of the bill of sale and encompasses:
a) 12 (twelve) months for equipment, accessories, parts, and pieces, including the legal warranty period of 90 (ninety) days.

Legal warranty

The customer has the period of 90 (ninety) days, from the date of emission of the bill of sale, to complain about apparent defects (easily observable in the product), such as the items that constitute the product's exterior and any other area accessible to the user, just like appearance parts and general accessories.

a) 90 (ninety) days for repairs or technical assistance

3.Warranty shall be granted to the buyer only in the face of the bill of sale (original or copy)

4. Warranty does not apply in the following cases or conditions:

- defects and damages caused by accidents, negligence, or reasons of force majeure ;
- defects and damages caused by inappropriate storage or lack of prolonged use ;
- defects and damages caused by improper use of the equipment ;
- defects and damages caused by improper operation or installation of the equipment ;
- vandalism;
- natural impacts (lightning, flooding, etc.);
- defects and damages caused by abnormal temperature conditions, voltage/frequency, or humidity out of the levels specified in the installation and operation manual, once proven;
- reconditioning, chrome plating, nickel plating, and painting.

5.Warranty shall be automatically canceled for equipment that:

- suffers modifications, adaptations, or any alterations performed by the client or by third parties without Digicon's written consent
- goes through maintenance or repairs by people not authorized by Digicon
- suffers alteration of serial number or violation of the identification label
- is not paid for in the conditions, amounts, and deadlines described in the bill of sale

6.Digicon is not responsible for eventual losses suffered by the down time of the equipment.

7.The repair of a warranted product will be performed inside the Digicon facilities.

digicon

**Headquarters/RS
Factory, Technical Assistance, and
Sales**

Rua Nissin Castiel, 640 - Distrito Industrial.
Gravataí/RS
Zip Code 94045-420
Sales: (0xx51) 3489.8700
Technical Assistance: (0xx51) 3489.8903
E-mail: vendas.acesso@digicon.com.br

**Office/ SP
Development, Technical Assistance, and
Sales**

Rua São Paulo, 82 - Alphaville. Barueri/SP
Zip Code 06465-130
Phone: (0xx11) 3738.3500
E-mail: vendas.acesso@digicon.com.br

Home page: www.digicon.com.br

